

USE AND MAINTENANCE MANUAL

Translation of the original instructions in Italian

DIM SUM LADY 700



Dear Customer,

thank you for choosing us. We are certain that this appliance will satisfy your needs and live up to your expectations.

We kindly ask you to read this Use and Maintenance Manual carefully in order to be able to use the appliance to its full potential. For any further information regarding use and maintenance, please do not hesitate to contact us. We will be delighted to answer any questions you may have.

Introduction

Warning on the ownership of information

- *In order to foster its policy of continual development and updating of the product, the Manufacturer reserves the right to make any modifications necessary to improve its basic features without having to give notice and without being under any obligation to do so. If the modifications do not change any safety aspects, the Manufacturer is not obliged to give notice of them in this document attached to the appliance.*
- *The Manufacturer also reserves ownership of this document and strictly forbids its reproduction or disclosure to third parties without prior authorization.*
- *Any illustrations or drawings in this document are merely simplified representations of the appliance; on the basis of any improvements and modifications made, they may not correspond to the actual appliance.*

Updating procedure

- *Updating and/or drafting of a new version of the above-mentioned document will only be carried out if the functional or safety aspects of the appliance are modified.*

Original version

- *This document was originally issued in Italian. In the event of any controversy arising due to the translation of the same, even if carried out by the Manufacturer, the reference text will be the Italian version alone.*

- Reproduction of this document, either in total or in part, is forbidden without prior written consent by the Manufacturer, who reserves the right to modify it without any obligation to give notice, unless this represents a safety risk.
- Drafted by: VEGA srl

| | | |
|----------|---|-----------|
| 1 | General information | 5 |
| 1-1 | Purpose and description of the manual | 6 |
| 1-2 | Correct manual storage | 8 |
| 1-3 | Identification data | 8 |
| 1-4 | Requests for assistance | 10 |
| 2 | Technical information | 11 |
| 2-1 | General description of the appliance | 12 |
| 3 | Safety information | 15 |
| 3-1 | Safety | 16 |
| 4 | Information for correct use | 19 |
| 4-1 | First use | 20 |
| 4-2 | Complete map of the controls | 21 |
| 4-3 | Tank filling and emptying | 22 |
| 4-4 | Appliance start and turning off | 22 |
| 4-5 | Recommendations for use | 23 |
| 4-6 | What to do in the event of long periods of inactivity | 23 |
| 5 | Maintenance information | 25 |
| 5-1 | Maintenance recommendations | 26 |
| 5-2 | Ordinary cleaning | 26 |
| 5-3 | Useful tips for stainless steel care | 28 |
| 5-4 | Troubleshooting | 30 |
| 6 | Instructions for qualified fitters | 31 |
| 6-1 | General information | 32 |
| 6-2 | Storage | 32 |
| 6-3 | Packaging | 32 |
| 6-4 | Technical specifications | 33 |
| 6-5 | Positioning and installation | 35 |
| 6-6 | Mains Electricity Connection | 38 |
| 6-7 | Water supply system connection | 39 |
| 6-8 | Inspection and start-up | 40 |
| 6-9 | Maintenance to be carried out by a fitter or qualified technician | 41 |
| 7 | Tables and annexes | 43 |
| 7-1 | Wiring diagram | 44 |

This page intentionally left blank

1 GENERAL INFORMATION

1-1 Purpose and description of the manual

This manual is an integral part of the appliance and aims to provide all the information necessary to:

- make operators fully aware of any safety issues;
- guarantee correct installation;
- ensure full understanding of its operating principles and correct, safe use;
- carry out any maintenance correctly and safely;
- dispose of the appliance safely and in compliance with applicable legislation concerning health and safety and environmental protection.

Correct operation of the appliance is guaranteed only if these regulations are complied with.

The Manufacturer declines any responsibility for: damage resulting from poor maintenance, incorrect use, tampering with or any use which does not comply with the terms and conditions indicated in this manual.

The Manufacturer reserves the right to modify any drawings, texts and technical specifications without prior notice or responsibility and without any obligation to update this manual each time.

In the event of problems in understanding this manual, please contact the Manufacturer.

This manual is divided into the following sections:

- Section **1** contains information regarding consultation of this manual and the data necessary to correctly identify the manufacturer and appliance.
- Section **2** contains general information, essential for knowing all about the appliance and its main parts, its permitted uses, its technical specifications, etc.
- Section **3** is dedicated to user safety.
- Section **4** addresses the user and contains instructions for correct use of the appliance.
- Section **5** contains information about maintenance, describing operations the user needs to carry out and those which must be carried out by a fitter or authorized technician. It also contains a chapter dedicated to troubleshooting, identifying the cause of problems and possible solutions.
- Section **6** is intended for qualified fitters and concerns correct installation of the appliance.
- Section **7**, if present, contains tables and annexes.

1.1.1 Symbol used

During machine use, it is possible to face situations for which special considerations and adequate close examinations are needed.

The following "graphic safety symbols" are used in this manual. They aim to highlight risks or important information:



DANGER

Draws attention to actions which, if not correctly carried out, may cause serious injury or death or may be a health risk for people and the environment.



WARNING

Draws attention to operations, procedures or actions which, if not carefully carried out, may cause serious damage to the appliance or product.



IMPORTANT

Draws attention to technical information or practical recommendations that ensure efficient and economical use of the appliance. Failure to comply with this information may void the warranty.

1.1.2 Abbreviations used

| Ref. | Description |
|-------|----------------------|
| Ann. | Annex |
| Chap. | Chapter |
| Fig. | Figure |
| Max. | Maximum |
| Min. | Minimum |
| Mod. | Model |
| Page | Page |
| Par. | Paragraph |
| Ref. | Reference |
| Tab. | Table |
| U.m. | Units of measurement |

Tab. 1 Abbreviations used

1-2 Correct manual storage

This manual must be handled with care and clean hands and it should never be placed on dirty surfaces. It should be stored in a cool, dry place.

No part of the manual should be removed, torn out or arbitrarily changed.



DANGER

This manual is an integral part of the appliance and must be kept until final disposal of the same.

1-3 Identification data

Check that the instruction manual corresponds to the appliance being referred to.

In the event of any request for information or technical assistance, it will be necessary to specify the model and type of appliance, as well as its serial number.

1.3.1 Appliance type and model

The appliance type and model are indicated on the identification plate.

1.3.2 Manufacturer

CASTA s.r.l.

Via F.lli Lumière, 11 (Z.I. Villa Selva) - 47122 FORLÌ (FC) - ITALY

Tel. +39 0543 782920 - Fax +39 0543 782925

<http://www.casta.com> E-mail: casta@casta.com

VAT no. 03497370407

1.3.3 Identification plate

The identification plate shown is applied directly to the appliance. It includes all appliance and manufacturer identification data and the CE mark of conformity.

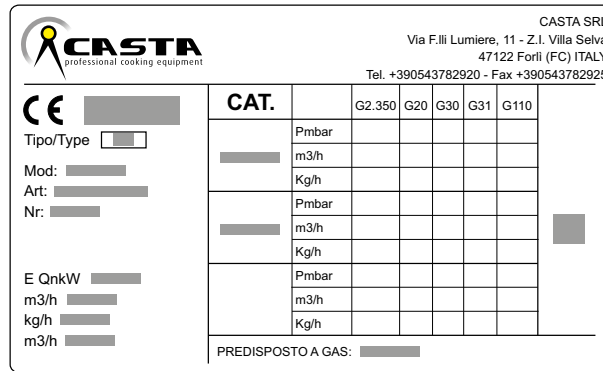

Fig. 1 Identification plate



Fig. 2 Plate position

1.3.4 Identification plates of the main components

The plates of all the commercial components not produced by the Manufacturer are applied directly to the relevant components, where their respective manufacturers originally placed them.

1.3.5 CE mark of conformity

The CE mark applied on the identification plate confirms that the appliance complies with the safety requirements specified in the following directives:

Directive 2014/35/EU (Low voltage)

Directive 2014/30/EU (Electromagnetic compatibility)

Regulation 2004/1935/EC (Materials intended to come into contact with food)

1-4 Requests for assistance

- As stated in the sales terms and conditions, the appliance is covered by a warranty. If during the validity period of the same any faults or breakages covered by the warranty should occur, the Manufacturer will repair or replace faulty parts after carrying out the necessary checks.
- Any modifications carried out by the user without express written authorization by the Manufacturer shall void the warranty and relieve the Manufacturer of any responsibility for damage caused by the faulty appliance. This also applies when non-original spare parts are used.
- For all of the above reasons, in the event of an emergency, we recommend contacting the Manufacturer's Technical Assistance Department directly.

CASTA s.r.l.

Via F.lli Lumière, 11 (Z.I. Villa Selva) - 47122 FORLÌ (FC) - ITALY

Tel. +39 0543 782920 - Fax +39 0543 782925

<http://www.casta.com> E-mail: casta@casta.com

VAT no. 03497370407



IMPORTANT

For any type of service request it is necessary to specify the data on the identification plate and the type of fault.

2 TECHNICAL INFORMATION

2-1 General description of the appliance

2.1.1 Intended uses

The appliance has been designed and manufactured for the professional catering sector.

The appliance function is to cook food (inside the suitable bamboo containers) thanks to the steam produced by boiling water.

Heating is obtained through an electric heating element installed under the tank.

Water temperature is controlled by a thermostat.

In order to use the appliance safely, it is essential to install it according to the laws, regulations and specifications applicable in the country where the appliance is to be installed.

2.1.2 Improper use

Improper use means any use of the appliance following criteria that do not comply with the instructions in this manual and that, as a result, may endanger safety.

The Manufacturer shall not be held responsible for any damage caused by improper use of the appliance.



DANGER

**Do not use the appliance other than for the use intended by the Manufacturer.
Improper use is forbidden.**

2.1.3 Main appliance parts

The picture and descriptions show the appliance fitted with all possible accessories. Depending on the model chosen, your appliance may be different.

- A. Tank
- B. Support
- C. Control panel
- D. Opening door
- E. Adjustable feet
- F. Heat extraction grille

The list indicates the appliance parts not shown in the figure but that are still considered among the main parts.

- Water dispenser inside the tank
- Extractable overflow hose; remove it to empty the tank
- Electric heating elements inside the tank
- Perforated plate where to place the bamboo container piles

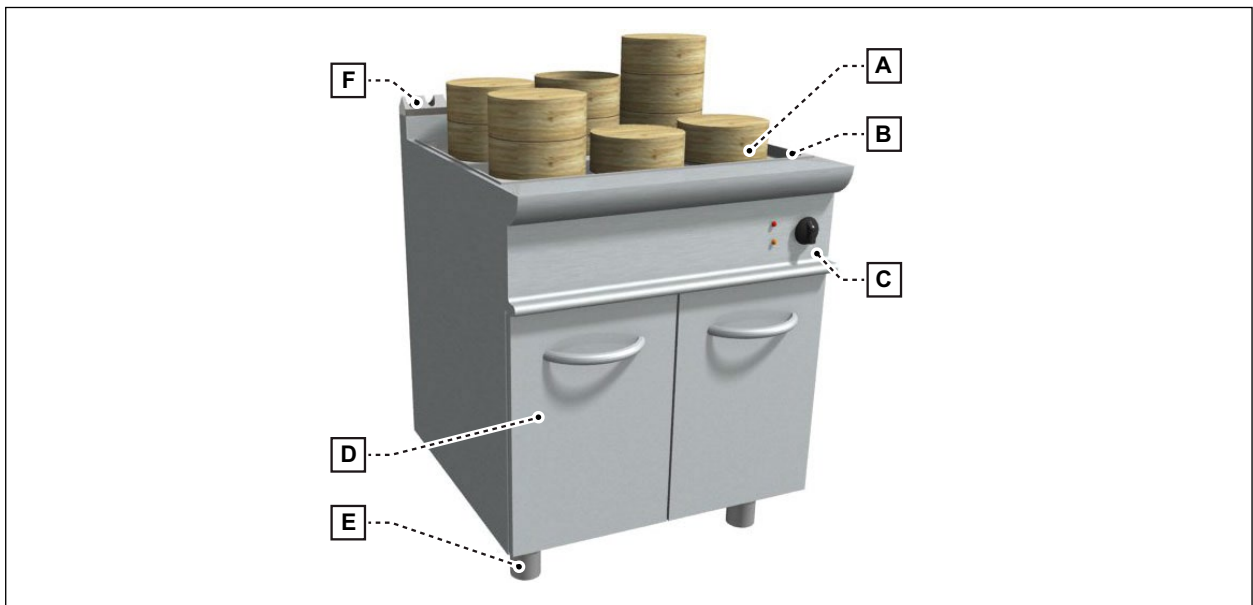

Fig. 3 Main appliance parts

2.1.4 Structural features

The main structure of the appliance is made in stainless steel 18/10 and stands on four height-adjustable feet.

The structural features of the main elements that make up the appliance are described below:

- Cool-grip knobs.
- Easy-clean, rounded surfaces;
- Stainless steel anti-corrosion tank with rounded corners;

IMPORTANT

The appliance is equipped with a safety thermostat that automatically cuts power off if the heating element temperature is higher than the set limit value (this condition may occur if the appliance is started without water inside the tanks).

3 SAFETY INFORMATION

3-1 Safety

- Use the appliance only for the purposes intended by the Manufacturer.
- Improper use of the appliance may result in a risk to the health and safety of people, as well as economic damage.
- As the appliance is used to prepare food for human consumption, special attention should be paid to everything related to hygiene and to keeping the appliance and surrounding area clean at all times.
- The appliance must be used by personnel trained on the appliance characteristics and functioning. Please refer to this manual. In case of more than one operator, consider handing out a copy of this manual to each one of them.
- Any maintenance operations requiring technical know-how or specific skills must be carried out exclusively by qualified personnel, properly trained in the specific field.
- To maintain hygiene and protect food from contamination, clean elements that come into direct or indirect contact with food and the surrounding areas thoroughly. Carry out these operations using only detergent products for food use and do not use flammable materials or materials containing substances that are harmful to people's health.
- In the event of long periods of inactivity, besides disconnecting all the power supplies, clean all internal and external parts of the appliance and the surrounding area thoroughly.

3.1.1 Safe use of the appliance

Since this appliance has been designed exclusively for professional use, it must only be used by qualified personnel.

- Never leave the appliance unsupervised when it is on.
- Do not leave any flammable objects, such as paper, plastic, rags, polystyrene, etc., near the appliance when it is on as they may start a fire.
- Keep the work area clean: do not leave any objects lying around the room as they might make it unsafe for personnel to move around.
- Do not obstruct air intake or heat extraction openings.
- **Do not start the appliance without water in the tank; make sure that during appliance operation there is always water inside the tank.**
- Before filling the tank make sure that the overflow hose is present.
- Do not put the food directly in the tank but use the suitable containers.
- Do not move the appliance when the tank is filled with water and when it has not completely cooled down.



WARNING

It is strictly forbidden to modify or carry out any type of intervention on the appliance, except those related to routine maintenance.

Any modification not explicitly approved by the Manufacturer will automatically void the warranty and the appliance conformity to the directives.

3.1.2 Safety instructions in the event of malfunctioning

In an emergency:

- Turn the electricity off.
- Close the water filling tap (if open).
- Contact the Manufacturer's Customer Care Service or a specialized technician.



DANGER

Turn off the appliance if any faults or malfunctioning occur.

3.1.3 Appliance disposal

The appliance has been manufactured using recyclable raw materials and does not contain any harmful or toxic substances.

All materials must be disposed of in compliance with the regulations applicable in the country of use of the appliance.

Always comply with environmental protection regulations.

This page intentionally left blank

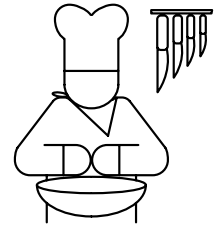

4 INFORMATION FOR CORRECT USE

4-1 First use

Clean the appliance thoroughly when using it for the first time.

Remove all packaging and clean the appliance using hot water and a sponge. Stainless steel parts must be cleaned with a non-abrasive detergent specifically designed for cleaning such surfaces. (see par. *Useful tips for stainless steel care*);

After cleaning the appliance, rinse thoroughly with clean water and dry with a cloth.

Do not use water jets to clean the appliance.

Before heating up the tank for the first time, fill it to the **maximum level** indicated by the relief mark on the inside of the tank. See *Fig. 5 Tank maximum/minimum filling level*.



WARNING

It is strictly forbidden to start the appliance without water in the tank; make sure that during appliance operation there is ALWAYS water inside the tank.

4-2 Complete map of the controls

This list shows the main appliance function controls.

- A. Water supply knob
- B. "Heating element on" warning light
- C. "Power supply" warning light
- D. Appliance start and stop knob
- E. Automatic water filling activation button

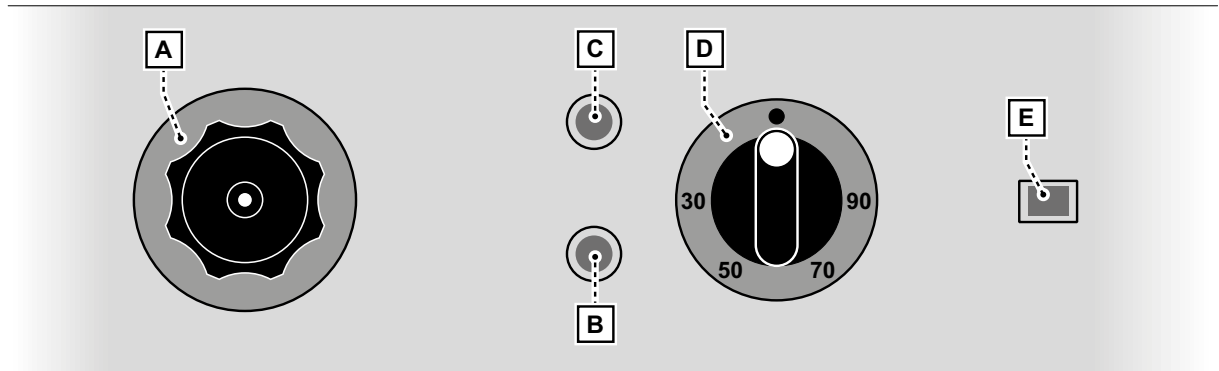

Fig. 4 Map of the controls

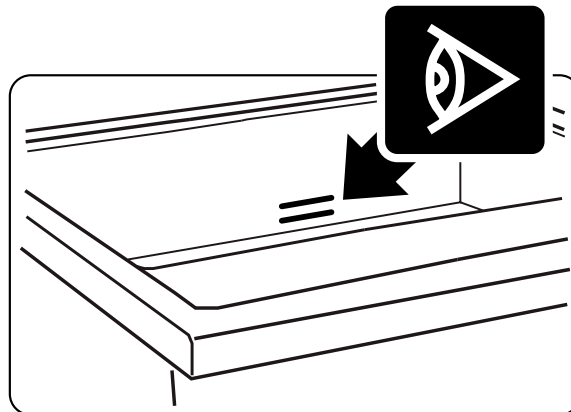

Fig. 5 Tank maximum/minimum filling level

4-3 Tank filling and emptying

Use the knob to fill the tank and proceed as shown.

- Make sure overflow hose is present.
- Use supply knob to fill the tank, then fill the tank up to the maximum level.
- During operation, keep the water between the maximum and minimum level.

To fill the tank automatically proceed as shown.

- Make sure overflow hose is present.
- Press button **(E)** to fill the tank.
- During operation, the water automatically stays between the maximum and minimum level.

To empty the tank proceed as shown.

- Remove the overflow hose to drain the water; the appliance is equipped with a special floor drain pipe.



WARNING

This operation must be carried out once the water has sufficiently cooled down.

4-4 Appliance start and turning off

To start the appliance proceed as shown.

| Position | Degrees |
|----------|---------|
| ● | OFF |
| 30 | 30° |
| 50 | 50° |
| 70 | 70° |
| 90 | 90° |

Tab. 1 Heating element adjustment knob

- Turn knob **(A)**. It is advisable to turn the knob to a 90° position for the first few minutes.
- The "Power supply" warning light **(C)** comes on.
- Set the water temperature using knob **(D)**.
- The "Heating element on" warning light **(B)** comes on.



IMPORTANT

The operating thermostat keeps water temperature to the set value by automatically turning on or off the installed electric heating element.

To turn the appliance off proceed as shown.

- Move knob **(A)** to the ● (Off) position.
- The two warning lights **(C)** - **(B)** go off.

4-5 Recommendations for use



IMPORTANT

During operation make sure there is always enough water inside the tank. The heating elements must be fully covered with water.



WARNING

Do not put the food directly in the tank but use the suitable containers.

4-6 What to do in the event of long periods of inactivity

If the appliance is not to be used for a certain period of time, it is necessary to:

- clean and dry the appliance;
- after cleaning and drying the appliance, protect it with a film of a suitable product (for example, Vaseline oil spray or a similar product);

This page intentionally left blank

5 MAINTENANCE INFORMATION

5-1 Maintenance recommendations

Keeping the appliance working to maximum efficiency, also thanks to scheduled maintenance recommended by the Manufacturer, will guarantee optimal performance, a longer lifespan and maintenance of all the safety requirements.

After **each use** or whenever necessary, clean the external parts of the appliance and surrounding area. At least **twice a year**, have an authorized technician check the appliance; **it would be advisable to enter a maintenance contract.**

Before cleaning proceed as shown.

- turn the appliance off;
- disconnect the appliance from the power supply;
- wait for the water to cool down and empty the tanks,



DANGER

Cleaning must be carried out once the appliance has cooled down.

5-2 Ordinary cleaning

Thorough daily cleaning of the appliance after use ensures perfect operation and a long lifespan. Clean using a damp cloth, water and soap or detergents and avoid abrasive or acidic products; these must not be used even to clean the floor near the appliance as the vapours may deposit on and deteriorate the steel. Rinse thoroughly with clean water and dry. Never use direct water jets so as not to cause infiltrations that may be harmful to the appliance.



IMPORTANT

To avoid any corrosion make sure to remove all salt residues on the tank sides or bottom.



IMPORTANT

Make sure that the water of the supply system does not carry any ferrous residues that can cause severe corrosion if they collect on the bottom of the tank.

| Description | Products |
|--|---|
| For washing and cleaning | Room temperature drinking water |
| For cleaning and drying | A non-abrasive cloth that does not leave any residues |
| Recommended detergent products | Detergents containing: |
| | - caustic potash at 5% (max) - caustic soda at 5% |
| Products for eliminating unpleasant smells | Rinse-aid products containing: |
| | - citric acid - acetic acid |

Tab. 2 Table of cleaning products

5.2.1 Main causes of deterioration or corrosion of stainless steel

This list shows the main causes of deterioration or corrosion of stainless steel.

- Use of abrasive or acid detergents, especially with a chlorinated base, such as hydrochloric acid or sodium hypochlorite (bleach); therefore, before purchasing a detergent product, ensure it does not cause steel corrosion;
- Stagnation of ferrous deposits (such as those produced by the rust present in the water that runs through the pipes, especially after a certain period of inactivity); such stagnation must thus be avoided. Also avoid using iron wool to remove food residues that are hard to eliminate; instead, use scourers or spatulas made of stainless steel or softer materials but, in any case, non-ferrous materials;
- Stagnation of acidic substances, such as vinegar, lemon juice, sauces, salt, etc. Do not allow such substances to stay in contact with the steel parts of the appliance for long periods. The evaporation of saline solutions on the surfaces is particularly harmful for them.

See also par. *Useful tips for stainless steel care.*

5-3 Useful tips for stainless steel care

Stainless steel is defined as such because it owes its resistance to corrosion to a thin oxide protective film which forms at a molecular level on its surface; it is created by the oxygen absorbed by exposure to the air of the metal itself. It is clear therefore, that anything that prevents the formation of this film and its permanence on the surface, such as foreign materials on it, food or salt residues, etc. reduce the resistance of stainless steel to corrosion.

Its resistance and duration, however, is also directly related to good maintenance during use and in choosing suitable materials and products for such maintenance.



IMPORTANT

Before using any detergent product for cleaning stainless steel, as well as for the floor underneath or near the appliances, ask your usual detergent supplier about the most suitable product to ensure this product cannot cause corrosion.

Daily cleaning: clean the surfaces thoroughly and frequently using a damp cloth. You can also use water and soap or common detergents that do not contain abrasive or coloured substances. Wipe only in the direction of the satin finish. Rinse with plenty of clean water and dry thoroughly.

Food stains or hardened leftovers: Wash any food stains using hot water before they harden. If they have already hardened, use water and soap or non-abrasive detergents, using a wooden spatula or soft stainless steel scourer. Rinse with plenty of water and dry well.

Limescale deposits: Limescale deposits on cookware bottoms, tanks, etc. must be removed using descaling products.

Scratches on the surfaces: If scratches or lines are detected on the surfaces, smooth them using very fine stainless steel wool or synthetic fibre abrasive felt pads, wiping in the direction of the satin finish. Rinse well and dry.

Elimination of possible fading of the steel caused by food stains or burns or heat stains: Use smooth stainless steel wool or synthetic fibre abrasive felt pads, wiping in the direction of the satin finish. Rinse well and dry. Take care not to scratch the surface.

Rust: If rust stains are detected, contact manufacturers of industrial detergents for a product capable of removing the stains. For this purpose, you can also use industrial products for removing limescale. After use and after rinsing with clean water, it may be necessary to use an alkaline detergent to neutralize the acid compounds still on the surface.



IMPORTANT

After cleaning the stainless steel, especially the external surfaces of the appliance, and once they are completely dry, protect them with products commonly found on the market.

Besides eliminating marks or rings, they also restore the shine to the steel and prevent the infiltration of humidity and dirt, which cause corrosion.

5.3.1 Products that must not be used on stainless steel

- Never use chlorinated products, for example bleach, hydrochloric acid or any other solutions deriving from the same. These products quickly attack stainless steel, causing irreversible corrosion.
- To clean the floors underneath and near the appliances, never use the products mentioned above, since vapours or drops that may fall on the steel produce similar corrosive effects to those described above.
- Never use iron scouring pads or leave them on the surfaces, since small deposits may remain on it and lead to the formation of rust; use a soft stainless steel wool or synthetic fibre abrasive felt pads, always wiping in the direction of the satin finish and taking care not to scratch the surfaces, then rinse and dry.



Fig. 6 Steel scouring pad



Fig. 7 Abrasive sponge



Fig. 8 Acidic substances

5.3.2 Some useful tips

- The pipes that supply water for use in pots, sinks, kitchens, washing machines, etc. inevitably surrender some rust, especially when taps are turned on after a period of inactivity or in case of new systems. Take care to prevent these oxides or ferrous deposits from coming into contact with the stainless steel for a long period of time, since they produce corrosion. It is always advisable to use galvanized pipes and to let the water run until it is perfectly clean.
- Avoid letting saline solutions evaporate, dry or stay in contact with stainless steel surfaces. For pots, never use coarse kitchen salt, which stays on the bottom and due to its weight cannot circulate and dissolve completely; this undissolved salt can cause corrosion. Therefore, it is advisable to crush it and add it to the pots when the water is boiling; if this is not possible and the salt is coarse, dissolve it in a separate container first. Avoid putting salt in pots of cold water or without water.
- When pots, washing machine compartments, bain-marie recipients, sinks, etc. are not used, they should preferably remain uncovered in order to keep the passivation film protecting the stainless steel stable and prevent it from coming into contact with possible aggressive agents.

5-4 Troubleshooting

Prior to start-up, the appliance has been tested by **qualified personnel**. The information contained in the following table is intended to help find and fix possible failures and faults that may occur during use.

Some of these problems can be solved by the user, whilst all others **require specific technical know-how and skills and must therefore be solved by qualified and expert personnel**.

| Problem | Likely cause | What should the user do | What should authorized personnel do |
|--|---|-----------------------------|--|
| The appliance does not come on | No input voltage | Contact the energy supplier | - |
| | Wrong connection to the terminal board | - | Check the correct connection to the input terminal board |
| | Bipolar switch interrupted | - | Replace the switch |
| White warning light does not come on but the appliance works | Light interrupted | - | Replace the white warning light |
| Yellow warning light does not come on but the appliance works | Light interrupted | - | Replace the yellow warning light |
| The heating element does not warm up with yellow light on | Heating element interrupted | - | Replace the heating element |
| The heating element does not warm up with yellow light off | Operating thermostat interrupted | - | Replace the operating thermostat |
| The heating element warms up non-stop without the intervention of the operating thermostat | Operating thermostat short circuit | - | Replace the operating thermostat |
| Automatic filling does not work | Solenoid valve or control unit fault or dirty sensors | Clean the sensors | Replace control unit or solenoid valve |

Tab. 3 Problems associated with the electrical system

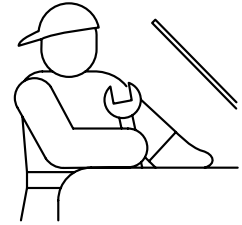

6 INSTRUCTIONS FOR QUALIFIED FITTERS

6-1 General information

The system and installation of the appliance must comply with existing UNI-CIG 8723 regulations and Italian Ministerial Decree dated 12 April 1996.

Appliance installation and maintenance **must be carried out by qualified and authorized personnel**, who must comply with the safety regulations applicable in the country where the appliance is to be installed.

6-2 Storage

If the appliance is stored in a warehouse at temperatures below 0°C, bring it to a temperature of at least +10°C before use.

6-3 Packaging

The appliance is usually packaged and shipped with all parts already assembled; therefore, when delivered, assembly is not necessary. The stainless steel parts and all framework panels are protected by an adhesive, scratch-resistant film.

The appliance is packaged inside a special wooden frame and placed on a pallet.

The packed appliance must be handled with care and kept in the correct position, according to the symbols present on the packaging.

During unpacking, ensure the appliance is in order and has all its components. When removing the scratch-resistant film, take care not to leave pieces of adhesive film on the panels.

It is advisable not to remove the packaging until the appliance is to be used so as to guarantee preservation of the same.

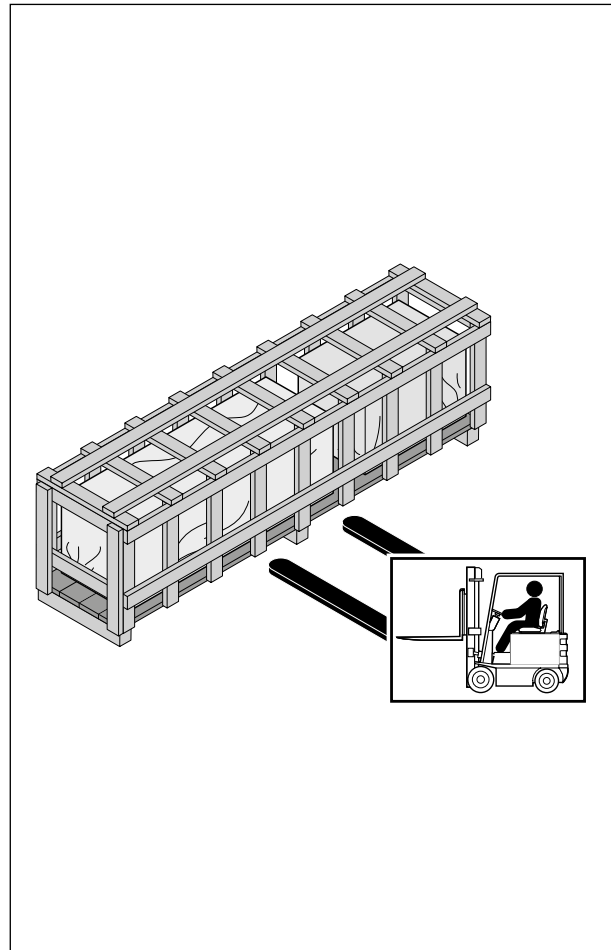

Fig. 9 Packaging



WARNING

Do not use cutters or any other sharp tools when unpacking. They may scratch the appliance surfaces irreparably.



WARNING

Packaging materials must be disposed of in compliance with the regulations applicable in the country where the appliance is to be installed. The various types of material must be separated and taken to special collection centres.

Always comply with environmental protection regulations.

6-4 Technical specifications

6.4.1 Composition and power of the appliance

| Model | External dimensions | Tank capacity | Weight | Packaging volume | Electric voltage | Electric power |
|-----------|---------------------|---------------|--------|--------------------|------------------|----------------|
| L7/DSE400 | 400x700 mm | 24 litri | 75 kg | 0,5 m ³ | 400V/3F 50Hz | 7 kW |
| L7/DSE800 | 800x700 mm | 55 litri | 135 kg | 0,9 m ³ | 400V/3F 50Hz | 14 kW |

Tab. 4 Technical specifications

6.4.2 Dimensions

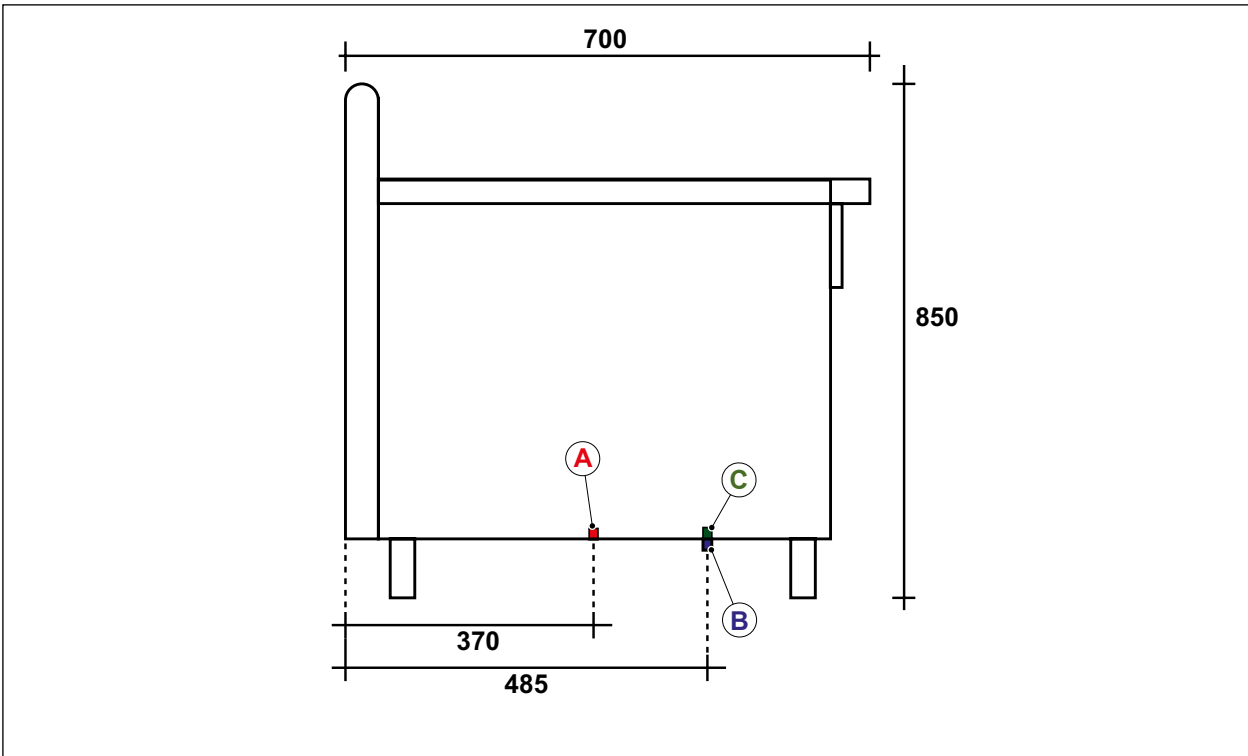

Fig. 10 DIM SUM dimensions

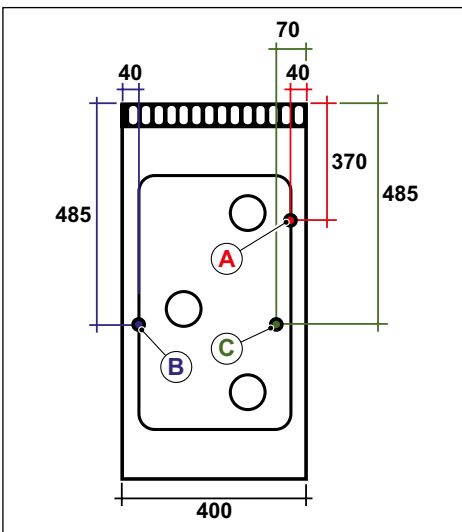

Fig. 11 Tank 400x700

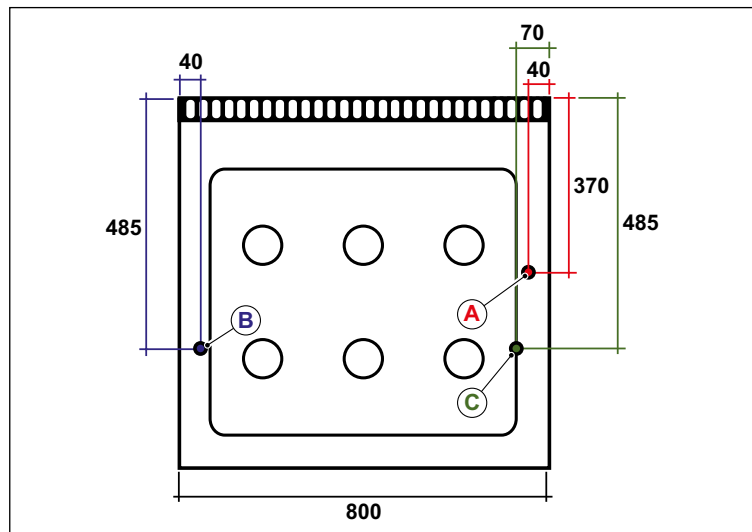

Fig. 12 Tank 800x700

- A. Power supply 3NAC400V
- B. Water inlet \varnothing 1/2"
- C. Water drain \varnothing 1"

6-5 Positioning and installation

The installation area must be equipped with all necessary power supply, ventilation, air intake and extraction connections, it must be properly illuminated and must comply with all health and safety requirements, in compliance with applicable laws, in order to avoid food contamination.

Ensure that the floor or support surface is flat and solid so that the base of the appliance is level and stable.



WARNING

The Manufacturer shall not be held responsible for any damage to people or objects caused by installation errors or by an inappropriate use of the appliance.

Any fault caused by wrong installation shall automatically void the warranty.

The system and installation of the appliance must comply with existing UNI-CIG 8723 regulations and Italian Ministerial Decree dated 12 April 1996.

Appliance installation and maintenance **must be carried out by qualified and authorized personnel**, who must comply with the safety regulations applicable in the country where the appliance is to be installed.

6.5.1 Positioning of the appliance



DANGER

The appliance must be installed at least 200 mm from flammable walls. This distance may be lower when the walls are fireproof or protected by heat insulating material.
The appliance is not suitable for built-in systems.



WARNING

Ensure that, once installed, the appliance can easily be reached by technical service personnel in the event of any fault occurring.

- Remove the appliance from its packaging and position it where it is to be used;
- Adjust the feet so that the appliance is level;
- Remove the transparent adhesive protective film from the surfaces, detaching it slowly to avoid leaving glue residues on the appliance.
- Connect the appliance to the premises electric network (chap. *Mains Electricity Connection* on page 38);
- Carry out water supply system connection (chap. *Water supply system connection* on page 39);
- Carry out drain pipe connection (chap. *Drain pipe connection* on page 39);

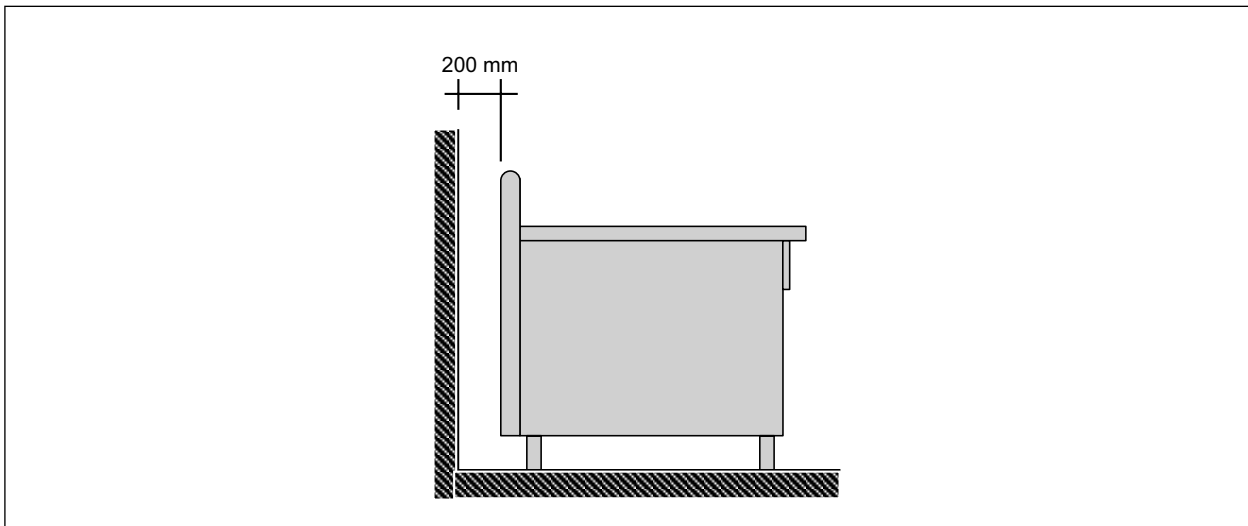

Fig. 13 Minimum distance from flammable walls

6.5.2 Ventilation of the installation premises and extraction of cooking heat and steam

The premises where the appliance is installed must have air intakes to ensure the correct functioning of the appliance and proper air exchange.

Air intakes must be of a suitable size, must be protected by grilles and must be placed in such a way that they cannot be obstructed.

To guarantee the complete extraction of heat and steam produced during water warm up, the appliance must be installed in well-ventilated premises (possibly under an extraction hood) in compliance with applicable regulations.

In case of installation under a hood (see *Fig. 16 Extraction through hood*), the final part of the appliance extraction duct must be about **1.8 m** from the appliance support surface; the outlet of the extraction duct must be placed within the basic perimeter of the hood.

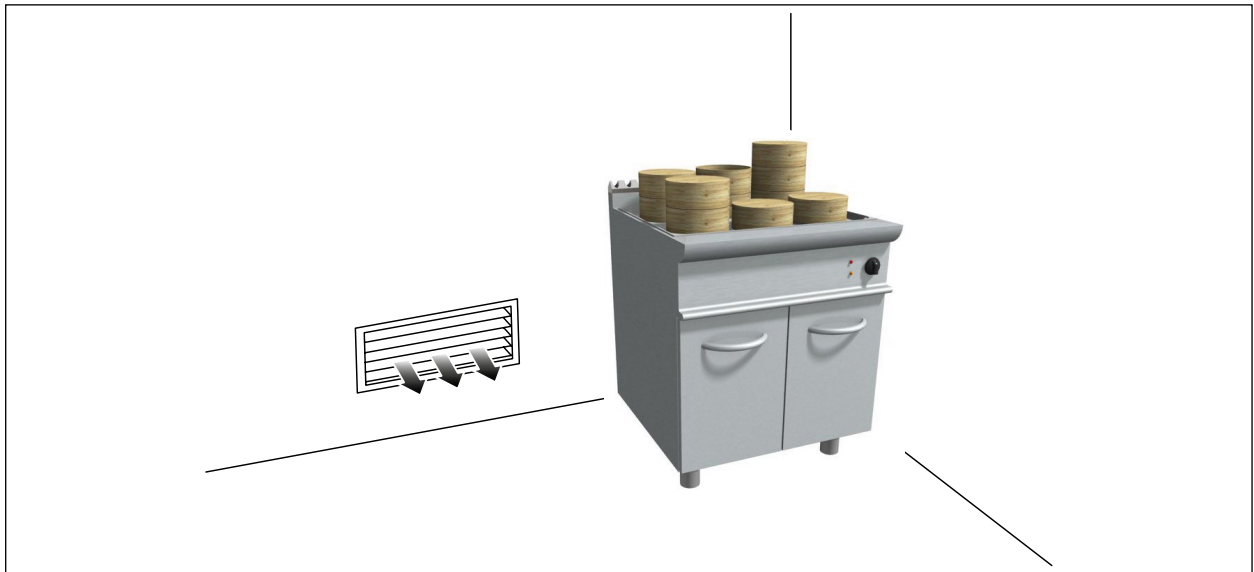

Fig. 14 Ventilation of the installation premises

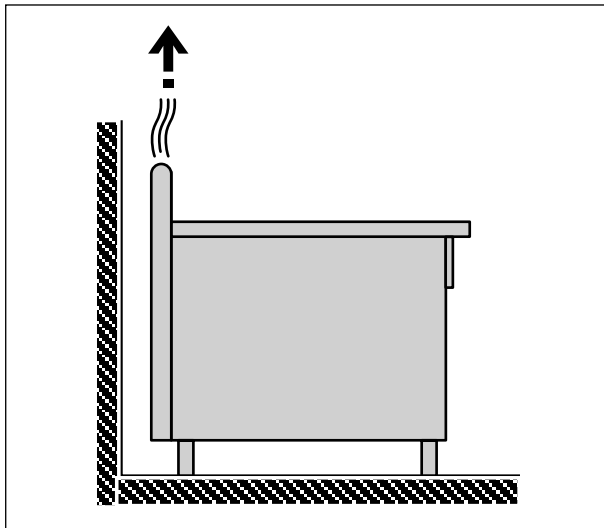

Fig. 15 Heat extraction

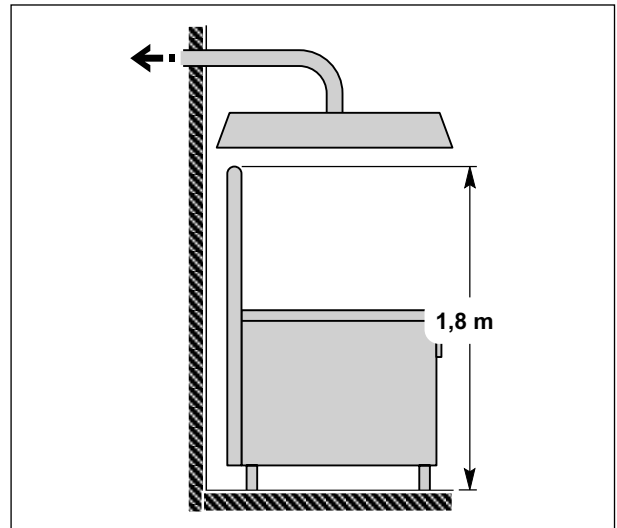

Fig. 16 Extraction through hood

6-6 Mains Electricity Connection



WARNING

All electrical operations necessary to install the appliance and the supply cable must be carried out by qualified electricians or technicians in compliance with applicable regulations.

- The appliance is designed to operate at the voltage indicated on the identification plate; before connection of the appliance to power mains, check that the voltage of the mains supply in the premises complies with the data indicated on the identification plate.
- The supply cable can only be installed by the Manufacturer or by a qualified operator.
- The supply cable must be made of rubber, with a quality level equal to at least H07RN-F and with conductors with a cross-section suitable for the maximum load to be carried.
- The supply cable must not be exposed to direct sources of heat; once installation and connection are complete, the supply cable should be placed in such a way that no part of it reaches a temperature that is 50°C higher than room temperature.
- The electrical safety of this appliance is guaranteed only when it is correctly connected to an efficient earthing system; it is necessary to check this essential safety requirement and if in doubt, ask qualified personnel to carry out a thorough check of the system.



IMPORTANT

Connect the appliance to an efficient earthing system!

The Manufacturer cannot be held responsible for any damage caused if the system is not earthed.

- An efficient omnipolar circuit breaker with a contact opening of at least 3 mm must be installed in the electrical supply system, fitted upstream of the appliance; automatic circuit-breaker switches can be used for this purpose.
- The omnipolar circuit breaker should be close to the appliance and easily accessible once installation is complete.
- The yellow-green earth cable must not be interrupted by the switch.



IMPORTANT

It is advisable to insert an integrated circuit-breaker switch with fuses.

6.6.1 Connection of the power supply cable

Connect the power supply cable (supplied) in compliance with applicable regulations; the power supply cable must be blocked using a cable clamp mounted on the appliance in order to prevent the risk of breakage.



WARNING

The earth cable must be longer (about 2 cm more) than the other conductor cables.

In the event of strong traction of the cable or breakage of the cable clamp, the earth cable must be disconnected after the other conductors.

6-7 Water supply system connection

For a correct connection to the water supply network follow these instructions.

- Always insert a cut-off tap between the appliance and the water supply pipes, in a position that makes it easy to handle and turn off after use.
- The water supply connector must be of rigid or flexible metal, use piping with proportionate cross-section.
- Check that the water supply pipes do not carry any rust or metal shavings inside the tank; make sure that no oxides or ferrous deposits remain in contact with the stainless steel for a long period of time since they produce corrosion (formation of rust). It is advisable to use galvanized pipes and to let the water run until it is perfectly clean.

In case of corrosion inside the tank, be aware that this is caused by iron oxides or metal shavings inside the tank for a long period of time and not by the stainless steel itself.



IMPORTANT

If possible, install a filter between the cut-off tap and the appliance; this will prevent ferrous deposits from going inside the tanks since, if they oxidise, they could damage the stainless steel.

6.7.1 Drain pipe connection

The appliance has a floor drain pipe; carry out drain pipe connection using plastic heat-proof pipes (at least 90°C) in compliance with the hygiene regulations applicable in the country where the appliance is to be installed.

6-8 Inspection and start-up



IMPORTANT

Before start-up, the system should be tested in order to assess the operating conditions of each component and detect any possible failures. At this stage it is important to check that all safety and hygiene conditions are strictly complied with.

6.8.1 Checking the electrical system

Press the electronic ignition switch to check its correct functioning.

Turn the appliance on according to the instructions for use, check the correct functioning of the heating element control devices, testing the various combinations.

6.8.2 Heat extraction check

Check that nothing obstructs air intake or heat extraction openings.

6.8.3 Checking ventilation of the installation premises

Carry out the following checks:

- check that the premises where the appliance is installed is well-ventilated.
- air intake openings must be placed in the lower part of the external walls, preferably opposite the wall where the extraction of steam produced during cooking is situated.
- air intake openings must be built in such a way that they cannot be obstructed.

6.8.4 Instructions for users

After testing, if necessary, train users so that they acquire all the necessary skills to start-up the appliance in safe conditions, as provided for by applicable regulations.



IMPORTANT

While explaining, always refer to this Use and Maintenance Manual.

6-9 Maintenance to be carried out by a fitter or qualified technician

The following maintenance operations must be carried out **at least once a year**:

- Check the efficiency of the cooking heat and steam extraction system (if any);
- Check adjustment device efficiency.

This page intentionally left blank

7 TABLES AND ANNEXES

7-1 Wiring diagram

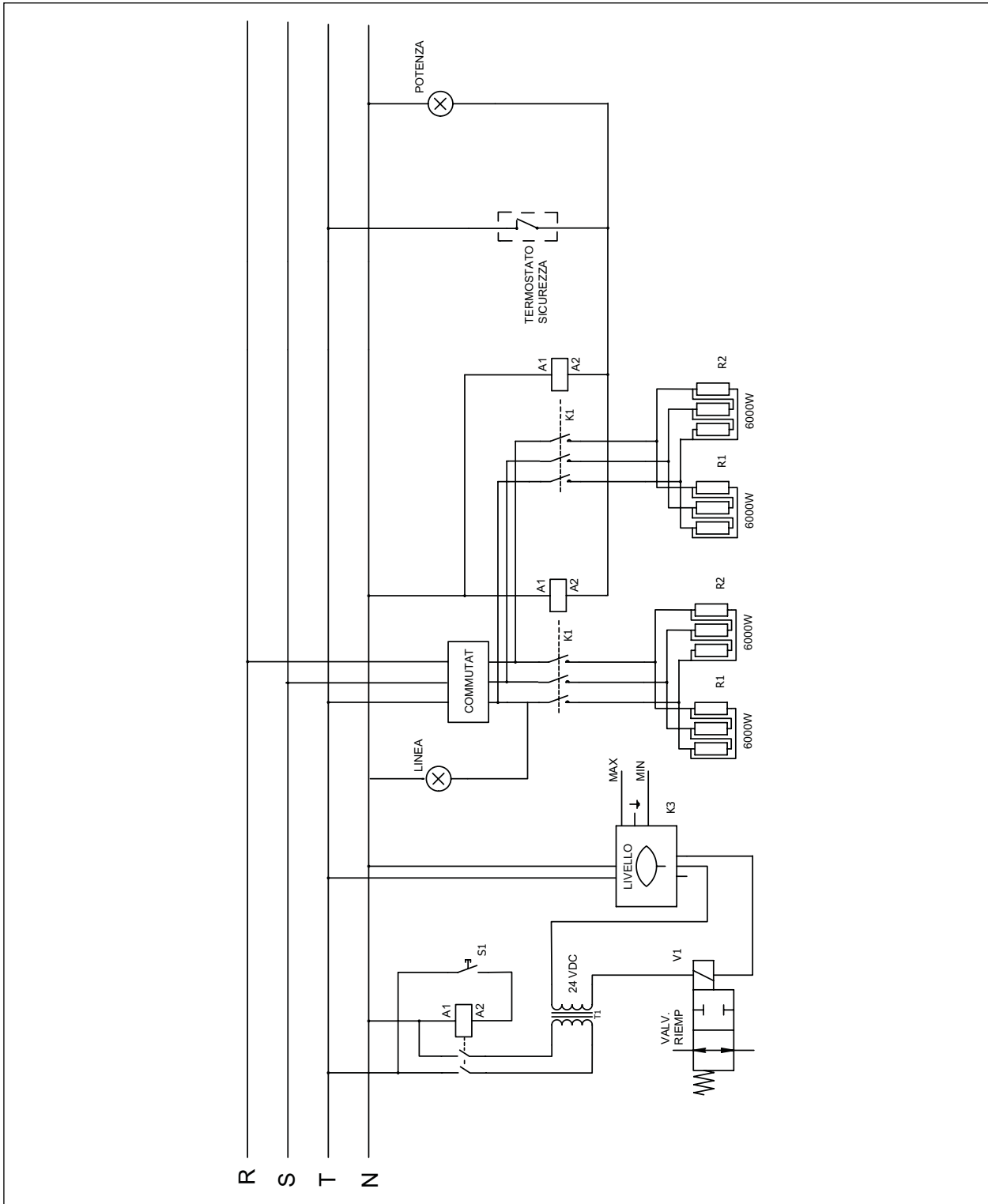

Fig. 17 Wiring diagram

This page intentionally left blank

CASTA s.r.l.
Via F.lli Lumière, 11 (Z.I. Villa Selva) - 47122 FORLI' (FC) - ITALY
Tel. +39 0543 782920 - Fax +39 0543 782925
<http://www.casta.com> E-mail: casta@casta.com
VAT no. 03497370407
