



INSTALLATION, MAINTENANCE AND USE INSTRUCTIONS FOR FREE-STANDING COOKERS

90x60 cm (type M9V)

60x60 cm (type M6V)

**READ THE INSTRUCTION BOOKLET BEFORE INSTALLING AND USING
THE APPLIANCE.**

**The manufacturer will not be responsible for any damage to property or to persons
caused by incorrect installation or improper use of the appliance.**

The manufacturer is not responsible for any inaccuracies, due to printing or transcription errors, contained in this booklet. In addition, the appearance of the figures reported is also purely indicative.

The manufacturer reserves the right to make changes to its products when considered necessary and useful, without affecting the essential safety and operating characteristics.

CONTENTS:

INSTALLER TECHNICAL MANUAL	pg. 2
Installing the cooker - Installation information	pg. 2
Ventilation and aeration of rooms.....	pg. 2-3
Gas connection	pg. 3
Adaptation to different types of Gas and burner adjustments.....	pg. 3-4
Electric connection	pg. 4-5
Three-phase electric connection	pg. 5
APPLIANCE MAINTENANCE - Replacing parts	pg. 5-6
USE AND MAINTENANCE MANUAL	pg. 6
Description of control panel and control types.....	pg. 6
Using burners.....	pg. 7
Use of the electric plates	pg. 7-8
Using the ceramic hob	pg. 8
Using the gas oven	pg. 8-9
Using the thermostat with switch in series.....	pg. 9
Using the electric thermostat.....	pg. 10
Using the 9+0 switch.....	pg. 10
Using the natural conventional electric oven	pg. 10-11
Using the ventilated electric oven.....	pg. 11-12
Using the gas grill.....	pg. 12
Using the electric grill - ventilated electric grill.....	pg. 12-13
Using the minute-minder	pg. 13
Using the analogue clock with timer.....	pg. 14
Electronic timer	pg. 14
Cleaning the appliance.....	pg. 14-5
After-sales technical service and spare parts.....	pg. 15

THIS APPLIANCE HAS BEEN DESIGNED FOR NON-PROFESSIONAL DOMESTIC USE.

INSTALLER TECHNICAL MANUAL



This appliance conforms with the regulations of European directive 2002/95/CE

This appliance is marked according to the European directive 2002/96/EC on Waste Electrical and Electronic Equipment (WEEE).

This guideline is the frame of a European-wide validity of return and recycling on Waste Electrical and Electronic Equipment.

INSTALLER INFORMATION

The installation, all adjustments, transformations and maintenance listed in this part of the manual must be carried out only by skilled personnel.

Improper installation may cause damage to persons, animals or property, for which the manufacture will not be held responsible.

The appliance safety or automatic adjustment devices may be changed during the service life of the system only by the manufacturer or by the duly authorised supplier.

INSTALLING THE COOKER

After having removed the various loose parts from the internal and external packing, make sure that the cooker is not damaged. In case of doubt, do not use the appliance and contact skilled personnel.

Keep all the dangerous packing parts (polystyrene foam, bags, cardboard, staples, etc.) away from children.

The appliance can be installed as a freestanding unit, next to a wall at a distance of no less than 20mm (Fig.2, Class 1 Installation) or inserted between two walls (Fig.1, Class 2 Subclass 1 Installation). A single sidewall that exceeds the height of the work surface is possible. This must be at a minimum distance of 70 mm from the edge of the cooker (Fig.2, Class 1 Installation)

Any walls of the adjacent furniture pieces and the wall behind the cooker must be made with heat-resistant material that can withstand a minimum overtemperature of 65 K.

The appliance can be installed as class 1 and as class 2 subclass 1.

WARNING: when the appliance is installed as class 2 subclass 1, the connection to the gas network must only use metal flexible pipes that conform with the national standards in force.

IMPORTANT INFORMATION FOR INSTALLING THE APPLIANCE

The cooker can be installed separately, as a freestanding unit, or between kitchen units or between a kitchen unit and the wall. The device must be installed in accordance with the regulations stated in UNI 7129 and UNI 7131 standards.

This appliance is not connected to devices which exhaust combustion products.

Special attention must be focused on the prescriptions described below regarding room aeration and ventilation. Any hanging cabinets installed above the work surface must be located at a distance of no less than 700 mm.

ROOM VENTILATION

To ensure that the appliance operate correctly, the room where it is installed must be continuously ventilated. The room volume should not be less than 25 m³ and the quantity of air needed shall be based on the regular combustion of gas and on the ventilation of the room. Natural air will flow through permanent openings in the walls of the room to be ventilated: these openings will be connected with the outside environment and shall have a minimum cross-section defined by the current national standards regarding room ventilation (see Fig. 3).

These openings shall be built so that they cannot be clogged.

Indirect ventilation is also permitted by taking air from the rooms adjacent to the one to be ventilated.

LOCATION AND AERATION

The gas cooking appliances must always evacuate the combustion products by means of hoods connected to chimneys, flues or directly outside (see Fig. 4). If a hood cannot be installed, it is possible to use a fan installed on a window or directly facing outdoors, to be operated together with the appliance (see Fig. 5), provided that there is strict compliance with the ventilation regulations.

APPLIANCE GAS CONNECTION

Before connecting the appliance to the gas network, make sure that the data on the label attached to the food warmer drawer or on the back of the cooker are compatible with what is indicated for the gas distribution network.

A label attached to the last page of this handbook and in the food warmer drawer (or on the back) of the appliance indicates the appliance adjustment conditions: type of gas and operating pressure.

IMPORTANT: This appliance must be installed in compliance with current national standards in force and used only in a well-ventilated room.

WARNING: It should be recalled that the appliance utilises a threaded 1/2" gas cylindrical male fitting according to UNI-ISO 228-1.

To connect the appliance to the gas network with a flexible rubber hose, a supplemental hose nipple fitting is needed (see Fig. 6) which is supplied with the appliance.

ADAPTATION TO DIFFERENT TYPES OF GAS FOR COOKER TYPE M6V

Before performing any maintenance operation, disconnect the appliance from the gas supply and electricity network.

REPLACING THE NOZZLES TO OPERATE WITH ANOTHER TYPE OF GAS FOR COOKER TYPE M6V:

Follow the instructions below to change the burner nozzles on the work surface:

- 1) Pull out the plug from the electric outlet to avoid any type of electric contact.
- 2) Remove the grids from the work surface (Fig. 7A-7B).
- 3) Remove the burners (Fig. 7A-7B).
- 4) Unscrew the nozzles using a 7 mm spanner, and replace them (Fig.8) with those needed for the new type of gas according to what is indicated in Table 1 for model M6 and in Table 2 for model M9

Follow the instructions below to change the oven burner nozzle:

- 1) Remove the oven level (Fig. 9A-9B).
- 2) Loosen the screw **V** and pull out the burner from the support being careful not to damage the ignition plug and the thermocouple (Fig. 10-11).
- 3) Unscrew the nozzle **R** (Fig. 10-11) using a 10 mm spanner (model M6) or a 7 mm spanner (model M9) and replace it with the nozzle needed for the new type of gas according to what is indicated in Table 1 for model M6 and in Table 2 for model M9.

Follow the instructions below to change the grill burner nozzle:

- 1) Loosen the screw **A** and pull out the burner from the support being careful not to damage the ignition plug and the thermocouple (Fig. 12).
- 2) Unscrew the nozzle **C** (Fig. 12) using a 7 mm spanner and replace it with the nozzle needed for the new type of gas according to what is indicated in Table 1 for model M6 and in Table 2 for model M9.

WARNING: After completing the above-mentioned replacements, the technician must adjust the burners, as described in the paragraph below, seal any adjustment and pre-adjustment devices and apply the label on the appliance, to replace the existing one, corresponding to the new gas adjustment. This label is contained in the spare nozzle bag.

TABLE N°1: Adaption to various types of gas APPLIANCE CATEGORY: II2H3+

Burner	Types of Gas	Pressare	Nozzle Diameter	Rater Capacity				Reduced Capacity		by-pass Diameter
		Mbar	1/100 mm.	g/h	l/h	kw	kcal/h	kw	Kcal/h	1/100 mm.
Auxiliary	Natural G20	20	72	-	95	1	860	0,48	413	34
	Butane G30	30	50	73	-	1	860	0,48	413	34
	Propane G31	37	50	71	-	1	860	0,48	413	34
Semi-Rapid	Natural G20	20	97	-	167	1,75	1505	0,6	516	36
	Butane G30	30	65	127	-	1,75	1505	0,6	516	36
	Propane G31	37	65	125	-	1,75	1505	0,6	516	36
Rapid	Natural G20	20	115	-	286	3	2580	1,05	903	52
	Butane G30	30	85	218	-	3	2580	1,05	903	52
	Propane G31	37	85	214	-	3	2580	1,05	903	52
Double Ring	Natural G20	20	135	-	334	3,5	3010	1,8	1548	65
	Butane G30	30	95	254	-	3,5	3010	1,8	1548	65
	Propane G31	37	95	250	-	3,5	3010	1,8	1548	65
Oven	Natural G20	20	125	-	286	3	2580	1	860	42
	Butane G30	28	85	218	-	3	2580	1	860	42
	Propane G31	37	85	214	-	3	2580	1	860	42
Grill	Natural G20	20	96	-	172	1,8	1548	-	-	NO
	Butane G30	28	65	131	-	1,8	1548	-	-	by-pass
	Propane G31	37	65	128	-	1,8	15480	-	-	

TABLE N°2: Adaption to various types of gas APPLIANCE CATEGORY: II2H3+

Burner	Types of Gas	Pressare	Nozzle Diameter	Rater Capacity				Reduced Capacity		by-pass Diameter
		Mbar	1/100 mm.	g/h	l/h	kw	kcal/h	kw	Kcal/h	1/100 mm.
Auxiliary	Natural G20	20	72	-	95	1	860	0,48	413	34
	Butane G30	30	50	73	-	1	860	0,48	413	34
	Propane G31	37	50	71	-	1	860	0,48	413	34
Semi-Rapid	Natural G20	20	97	-	167	1,75	1505	0,6	516	36
	Butane G30	30	65	127	-	1,75	1505	0,6	516	36
	Propane G31	37	65	125	-	1,75	1505	0,6	516	36
Rapid	Natural G20	20	115	-	286	3	2580	1,05	903	52
	Butane G30	30	85	218	-	3	2580	1,05	903	52
	Propane G31	37	85	214	-	3	2580	1,05	903	52
Double Ring	Natural G20	20	131	-	334	3,5	3010	1,8	1548	65
	Butane G30	30	95	254	-	3,5	3010	1,8	1548	65
	Propane G31	37	95	250	-	3,5	3010	1,8	1548	65
Oven	Natural G20	20	150	-	429	4,5	3870	2	1720	70
	Butane G30	28	95	327	-	4,5	3870	2	1720	70
	Propane G31	37	95	321	-	4,5	3870	2	1720	70
Grill	Natural G20	20	115	-	191	2	1720	-	-	NO
	Butane G30	28	68	145	-	2	1720	-	-	by-pass
	Propane G31	37	68	143	-	2	1720	-	-	

BURNER ADJUSTMENT

1) Primary air adjustment:

Oven burner adjustment: follow the instructions below to adjust the primary air for the oven burner:

- 1) Remove the oven bottom.
- 2) Loosen the screw **P** and adjust the position **X** of the Venturi cone (Fig. 12) according to the measurements indicated in table 3.

Grill burner adjustment: to adjust the grill burner loosen screw **P** and adjust the position **X** of the Venturi cone (Fig. 13) according to the measurements indicated in table 3.

TABLE N°3: Burner primary air regulation (indicative)

Type of gas	BURNER	
	Oven (mm)	Grill (mm)
	M6	M6
Natural G20	fully open	fully open
Butane G30	fully open	fully open
Propane G31	fully open	fully open

2) Burner "MINIMUM" adjustment:

Work surface burner adjustment: follow the instructions below to adjust the work surface burner minimum:

- 1) Light the burner and set the knob to the MINIMUM position (small flame).
- 2) Remove the knob of the valve that is press fit on the rod of that valve.
- 3) If the cooker is not equipped with safety valves on the surface burners, insert a small slotted screwdriver into the hole on the valve rod (Fig. 14) and turn the choke screw to the right or left until the burner flame is adjusted to minimum. If the cooker is equipped with safety valves, the choke valve is not located in the rod hole, but on the valve body (see fig. 15).

4) Make sure that the flame does not go out when switching quickly from the MAXIMUM to the MINIMUM position.

Oven burner adjustment: follow the instructions below to adjust the minimum:

- 1) Light the burner setting the knob to the MAXIMUM position.
- 2) Close the oven door and operate the oven for at least 10 minutes.
- 3) Set the knob to the MINIMUM position (corresponding to 120°) and then remove it.
- 4) With a slotted screwdriver turn the choking screw (see figure 16) and, while observing the flame at the same time through the cooker porthole, evaluate the consistency of the flame so it remains on when switching quickly from the MINIMUM to the MAXIMUM position.

WARNING: The above-mentioned adjustment should be made only with methane gas burners, while for those operating with liquid gas the screw must be locked at the end in a clockwise direction. The grill burner always operates at maximum and therefore no minimum adjustment is required.

APPLIANCE ELECTRIC CONNECTION:

The electric connection must comply with the current legal standards and regulations.

Before making the connection, check that:

- The system electrical rating and the current outlets are adequate for the maximum power output of the appliance (see the label applied to the bottom of the casing).
- The outlet or the system is equipped with an efficient ground connection in accordance with the current legal standards and regulations. The company will not be responsible for the non-compliance with these instructions.

When the connection to the power supply network is made using an outlet:

- If the power cord is supplied without a plug, apply a standard plug that is suitable for the load indicated on the label. Connect the wires according to the diagram shown in FIG.17 and check that:

letter L (phase) = brown wire;

letter N (neutral) = blue wire;

ground symbol \equiv = green-yellow wire;

- The power cord must be positioned so that an overtemperature of 75 K will not be reached at any point.
- Do not use reductions, adapters or splitters since they might cause false contacts and lead to dangerous overheating.

When the connection is made directly to the electric network:

- Use a device that ensures disconnection from the mains in which the contacts are opened to a distance that permits complete disconnection according to the conditions for over-voltage category III.
- Remember that the ground wire must not be interrupted by the circuit-breaker.
- As an alternative, the electric connection can also be protected by a high-sensitivity residual current circuit-breaker.
- It is highly recommended to attach the special green-yellow ground wire to an efficient ground system.

WARNING: If the power cord is replaced, the ground wire (yellow-green) connected to the terminal, should be longer than the other wires by about 2 cm.

TABLE N°4 : TYPES OF POWER CORDS

Work surface operation	Oven operation	Cross section			
		230V ~	230V 3~	400V 2N~	400V 3N~
Only gas burner	Gas oven / Gas grill	3x0.75mm ²	-	-	-
	Gas oven / Electric grill	3x1mm ²	-	-	-
	Electric Oven	3x1mm ² (M6) 3x1,5mm ² (M9)	-	-	-
	Ventilated Electric Oven	3x1,5mm ²	-	-	-
Gas burner + 1 hot plate	Gas oven / Gas grill	3x1mm ²	-	-	-
	Gas oven / Electric grill	3x1,5mm ² (M6) 3x2,5mm ² (M9)	-	-	-
	Electric Oven	3x1,5mm ² (M6) 3x2,5mm ² (M9)	-	-	-
	Ventilated Electric Oven	3x2,5mm ²	-	-	-
Gas burner + 2 hot plate	Forno elettrico statico	3x2,5mm ²	4x1,5mm ²	4x1,5mm ²	5x1,5mm ²
	Forno elettrico ventilato multi-9	3x2,5mm ²	4x1,5mm ²	4x1,5mm ²	5x1,5mm ²
4 hot plate	Forno elettrico statico	3x2,5mm ²	4x1,5mm ²	4x1,5mm ²	5x1,5mm ²
	Forno elettrico ventilato multi-9	3x2,5mm ²	4x1,5mm ²	4x1,5mm ²	5x1,5mm ²
Ceran	Forno elettrico statico	3x2,5mm ²	4x1,5mm ²	4x1,5mm ²	5x1,5mm ²
	Forno elettrico ventilato multi-9	3x4mm ²	4x1,5mm ²	4x1,5mm ²	5x1,5mm ²

ATTENTION: The appliance conforms with the regulations of directives 90/396EEC (Gas Directive) regarding gas appliances for domestic use and the like, 93/68 and 73/23 (Low Voltage Directive) regarding electrical safety and 2004/108/CE, 93/68 and 89/336 (EMC Directive) regarding electromagnetic compatibility.

THREE-PHASE ELECTRIC CONNECTION

The cookers that can also be connected to three-phase systems normally are factory built for the single-phase 230V connection and are supplied with a power cord. Based on the connection system used, install the power cord type indicated in table No.4.

To use the selected connection system change the jumpers on the terminal strip as indicated in the diagram of Fig.18

APPLIANCE MAINTENANCE

ATTENTION: IMPORTANT WARNINGS

For cookers resting on a base

ATTENTION: If the cooker rests on a base, take the measures necessary to prevent the cooker from sliding along the support base.

For cookers with glass covers

ATTENTION: Before opening the appliance's glass cover, carefully remove all liquid residues from the top of it.
ATTENTION: Before closing the appliance's glass cover, make sure that the work surface has cooled.

For cookers with electric ovens

The unit becomes hot during use. Do not touch the heating elements inside the oven.

For cookers with electric ovens

ATTENTION: The accessible parts can become hot during use. Keep children away from the appliance.

For the food warmer compartment (or drop leaf in our case)

ATTENTION: The internal parts of the food warmer can become hot during use.

For glass doors

Do not use abrasive cleaning products or metal spatulas with sharp edges to clean the oven door's glass since this could scratch the surface and the glass could break.

Do not use steam cleaners to clean the appliance.

DOOR GUARD

The M9 and M9V cookers with strips of stainless steel on the oven door can be equipped with a protective grating that can be installed on the door. Such grating is available on the service post sale (see Fig.43).

REPLACING PARTS

Before performing any maintenance operation, disconnect the appliance from the gas supply and electricity network.

To replace parts such as knobs and burners, just remove them from the seats without disassembling any part of the cooker.

To replace parts such as nozzle supports, valves and electric components follow the procedure described in the burner adjustment paragraph. To replace the valve or the gas thermostat, it is also necessary to disassemble the two rear gas train brackets, loosening the 4 screws (2 per bracket) that attach it to the rest of the cooker and, unscrew the nuts that attach the front burner valves to the control support, after removing all the knobs. To replace the gas or electric thermostat, also disassemble the rear cooker guard, loosening the relative screws, to be able to pull out and reposition the thermostat bulb.

To replace the oven bulb, just unscrew the protection cap that projects out inside the oven. (Fig.19)

WARNING: Before replacing the bulb, disconnect the appliance from the electric power supply.

WARNING: The power cord supplied with the appliance is connected to that appliance with an X type connection (in compliance with standards EN 60335-1, EN 60335-2-6 and subsequent amendments) for which it can be installed without the use of special tools, with the same type of cord as the one installed.

If the power cord becomes worn or damaged, replace it based on the information reported in table 4 .

WARNING: If the power cord is replaced, the installer shall ensure that the ground cable is longer than the phase cables and also shall comply with the warnings regarding the electric connection.

Greasing the valves:

If it becomes difficult to operate the valve, it should be greased immediately by following the instructions listed below:

- 1) Disassemble the valve body by loosening the two screws located on the body of the valve.(Fig.20)
- 2) Extract and clean the seal cone and its housing with a rag soaked with thinner.
- 3) Lightly grease the cone with a special grease.
- 4) Insert the cone, moving it several times, remove it again, remove the excess grease and make sure that the gas passage ways are unobstructed.
- 5) Replace all the pieces by reversing the order in which they were disassembled and check that the valve operates correctly.
- 6)To replace the power cable, lift the terminal board's cover and replace the cable. To access the terminal board in cookers with a 3x2.5mm² cable, the back panel on the rear of the appliance must be removed.

USE AND MAINTENANCE MANUAL

GAS BURNER DIMENSION

Burner	Dimension (mm)
Auxiliary	Ø 50
Semi-rapid	Ø 70
Rapid	Ø 95
Fish	55x230
Ultra-rapid	Ø 130

CERAN AND ELECTRIC HOT PLATE DIMENSION

TYPE OF PLATE	DIMENSION
Electric hot plate	Ø 145
Electric hot plate	Ø 180
Electric hot plate infrared	Ø 145 left rear 1200W
Electric hot plate infrared	Ø 145 right rear 2100W
Electric hot plate infrared	Ø 145 right front 1200W
Electric hot plate infrared	Ø 180 left front 1700W
Electric hot plate hi light	Ø 145 left rear 1200W
Electric hot plate hi light	Ø 170/265 left rear 1400/2200W
Electric hot plate hi light	Ø 145 left rear 1200W
Electric hot plate hi light	Ø 180 left rear 700/2100W

CONTROL PANEL DESCRIPTION

On the control panel, small symbols show the function of each knob or key. Here as follows are the several controls that a cooker can have:

the symbol  shows the disposition of burners on the worktop, the full dot identifies the burner in object (in this case the rear burner on the right).

the symbol  shows the running of any oven (gas oven with gas grill, gas oven with electric grill, static oven, 9 positions switch)

the symbol  shows the electric thermostat for electric fan oven

the symbol  shows the minute minder

the symbol  shows the operating key for the rotisserie (only gas oven)

the symbol  shows the oven fan working button as to allow the oven to operate with fan assisted gas. The fan operation of the oven prevents the operation of the electric grill, which therefore cannot be used with the fan in action.

the symbol  shows the ignition key for the oven light (all except the electric fan oven)

the symbol  shows the push-button for burner ignition

the symbol  shows if keys are in position "on" or "off"

USING BURNERS

A diagram is etched on the control panel above each knob which indicates which burner corresponds to that knob. The burners can be ignited in different ways depending on the type of appliance and its specific characteristics:

- **Manual lighting (it is always possible even when the power is cut off):** Turn the knob anticlockwise that corresponds to the burner selected, setting it to the MAXIMUM position at the etched star (large flame Fig.23A-23B-23C) and place a lit match up to the burner.

- **Electric ignition:** Turn the knob counterclockwise that corresponds to the burner selected, setting it to the MAXIMUM position (large flame Fig. 23A-23B-23C) and keep on pressing the knob in correspondence of the ignition symbol marked with a star (for cookers equipped with ignition trough knob) or press the ignition button marked with a star and release it as soon as the burner has ignited.

- **Burner ignition equipped with safety device (thermocouple)(fig.22):** Turn the knob anticlockwise that corresponds to the burner selected, setting it to the MAXIMUM position at the etched star (large flame Fig. 23A-23B-23C), press the knob and activate one of the above-mentioned ignition devices. Once ignited, keep pressing the knob for about 10 seconds to allow the flame to heat the thermocouple. If the burner goes out after releasing the knob, repeat the entire operation.

Note: It is recommended not to try to ignite a burner if the relative flame cap is not in the correct position.

Tips for using burners correctly:

- Use suitable pots for each burner (see tab. 5 and Fig. 21).
- When the liquid is boiling, turn the knob to the MINIMUM position (small flame Fig. 23A-23B-23C).
- Always use pots with a cover.

TABLE N°5

BURNER	PAN DIAMETER recommended (cm)
Auxiliary	12-14
Semi-rapid	14-26
Rapid	18-26
Double ring	22-26

ATTENTION: Use pots with a flat bottom

WARNING: If the power is cut off, the burners can be lit with matches. When cooking foods with oil and fat, which are very flammable, the user should not leave the appliance unattended. If the appliance is equipped with a glass cover, such a cover may break when heated. Turn off all burners before lowering the cover. Do not use sprays near the appliance when it is being used. When using the burners, make sure that the handles of the pots are correctly positioned. Keep children away from the appliance. If equipped with a cover, before being closed, any food deposits should be cleaned off the built-in surface.

NOTE: The use of a gas cooking appliance produces heat and humidity in the room where it is installed. Therefore, proper aeration in the room is needed while ensuring that natural ventilation openings remain unobstructed (Fig.3) and activating the mechanical aeration device/exhaust hood or electric fan (Fig. 4 and Fig. 5). Intensive and continuous use of the appliance may require additional aeration, for example by opening a window, or more efficient aeration by increasing the power of the mechanical exhauster, if installed.

USE OF THE ELECTRIC PLATES

The plates are controlled by a switch with 6 positions (Fig. 24A-24B).

The plates can be inserted by rotating the knob onto the desired position. On the front of the appliance there is a design showing which plate the knob refers to. The insertion of the plate is shown by the indicator light which is also found on the front panel of the appliance.

How to use an electric plate:

When you use the plate for the first time or after a long period over which the plate has not been used, you are advised to use the plate on position 1 for about 30 minutes in order to eliminate any humidity absorbed by the isolating material inside. As an indication we give a table with the necessary rules to follow for the best use of the electric plates.

WARNING: When using the plate for the first time or after a long period over which the plate has not been used, in order to eliminate any humidity absorbed by the isolating material it is necessary to use the plate for about 30 minutes on position 1 of the switch.

PLATE 1500W	Watt	COOKING POSSIBILITIES
0	0	Plate switched off
1	135	To melt butter, chocolate etc. - To heat up small quantities of liquid
2	165	To heat up larger quantities of liquid - to prepare creams/sauces with long cooking times
3	250	To thaw foods, cooking boiling temperatures
4	500	To cook roasts of delicate meat and fish
5	750	For roast of chops and steaks, for large boiled foods
6	1500	To boil large quantities of water, to fry

For a correct use remember the following:

- Dry the bottom of the pan before putting it on the plate.
- Use pans with a flat bottom and in thick metal (see Fig. 25).
- Never use pans which are smaller than the plate.
- Switch on the current after you have put the pan on the plate.
- After use, to keep the plate in good condition, always treat the plate with normal products for electric plates which are available on the market so that the surface is always clean; doing this will avoid any eventual oxidisation (rust).
- Even after use the plates stay hot for a long time and so do not put your hands or other objects on the plates so as to prevent possible burns.
- When the plates are in use make sure that the pan handles are positioned correctly. Keep children away. – When cooking foods with oil and fat, which can easily set alight, the user must not leave the appliance.

WARNING: As soon as you see a crack in the surface of the plate immediately disconnect the appliance from the mains.

USING THE CERAMIC HOB

The work surface has 4 cooking areas with different heating levels and diameters. The positions are clearly indicated by circular areas that are not etched. Heating takes place within these marked areas. If 1 or 2 cooking areas are used, the other surface remain cold. It is recommended to use special utensil for electric cooking to ensure efficient use and to save energy. The bottom of the surface should be thick and flat to guarantee the best cooking. The diameter of the base of the pots (or other containers) should be as close as possible to the diameter of the plate being used, if it is smaller, the energy will be wasted since the heat generated will be partially dispersed by the uncovered surface of the plate. The surface of the hob and the base of the container must be clean following these hints will save energy and heat.

How to use the ceramic hob.

Each cooking area is controlled by a thermostat or by an energy regulator that is used to select a variable temperature. When the boiling point is reached, the temperature can be reduced allow the food to slow boil. Practice will indicate the

right time to allow the foods to slow boil, but obviously this depends on the food and the type of pot. The correct combination will save time and energy.

WARNING: Your CERAN ceramic hob is resistant to thermal shocks and is not unaffected by heat or cold. Accidental impacts with a heavy casserole dish will not damage the hob. However, a special type of impact, causer by a heavy object such as a salt container or a spice bottle on the edge or corner of the hob, may break the surface.

USING THE GAS OVEN

GAS OVEN:

All the gas oven cookers are equipped with a thermostat and safety device to adjust the cooking temperature. The oven temperature is set by turning the knob counterclockwise to match the indicator with the temperature selected. The gas oven can be combined with a gas grill or an electric grill. See the specific pages for use information.

FAN GAS OVEN:

Operating the fan of the oven by means of the appropriate switch situated on the control panel, the circulation of warm air guarantees a uniform heat distribution. The preheating of the oven can be avoided. However for delicate baking, it is preferable to warm the oven before introducing the baking-pan. The baking system with the fan convection changes in part the various traditional baking notions. When roasting meat it is not necessary to turn the meat any more and for a roast on the spit, it is not indispensable to use the spit-roaster, but is sufficient to put the meat directly on the grate.

With the use of the fan gas oven, the baking temperatures are slightly lower of about 10-15°C compared to those in use with the traditional gas oven. The fan operation of the oven prevents the operation of the electric grill, which therefore cannot be used with the fan in action.

The oven can also be used in a traditional way, (by not activating the fan) for foods requiring heat from the bottom, e.g. pizza.

WARNING: If the burner flames are extinguished accidentally, turn off the control knob and do not try to relight the oven until after at least 1 minute.

TABLE N°6

THERMOSTAT SETTING	TEMPERATURE °C
1	120°C
2	140°C
3	160°C
4	180°C
5	200°C
6	225°C
7	245°C
8	270°C

The oven burner can be ignited in different ways:

- **Manual lighting** (it is always possible even when the power is cut off):

To light the oven, open the oven door and turn the knob so the no. 8 on the scale matches the indicator (fig.26A-26B-26C-26D). At the same time put a lit match next to the ignition tube that is visible on the oven level (fig.27A for cooker type M6V)(fig.27B for cooker type M9V). Then press the thermostat knob (this makes the gas start to flow) and keep it pressed, after the burner has been completely lit, for 10 seconds. Release the knob and make sure that the burner remains on, otherwise repeat the operation.

- **Electric ignition** (only for the models equipped with this device):

In this case, first open the oven door, then turn the knob to the maximum temperature setting (number 8). Then press the thermostat knob (models with ignition trough knob). Wait about 10 seconds after the burner has been completely lit and then release the knob. Make sure that the burner remains on, otherwise repeat the operation. As for cookers without ignition trough knob, press the thermostat knob and the key with the spark symbol, wait about 10 seconds after the burner has been completely lit and then release the knob. Make sure that the burner remains on, otherwise repeat the operation.

The ignition device should not be used for more than 15 seconds. If after that period the burner still has not been lit, do not use the device and open the door of the room or wait at least 60 seconds before trying to light the oven again.

WARNING: when trying to light the oven, the door must always be open. When using the oven, leave the cooker cover open to prevent it from overheating.

NOTICE: when using the oven for the first time it should be operated for 15-30 minutes at a temperature of about 250° without cooking anything inside in order to eliminate any moisture and odours from the internal insulation.

During normal oven use, after lighting the burner and setting the desired temperature, wait about 15 minutes before putting in any food to preheat the oven.

The oven is equipped with 5 guides at different heights level (fig.28) which can be used to insert shelves or the tray. To keep the oven as clean as possible it is recommended to cook meat on the tray or on the shelf that has been inserted inside the tray. The table below lists the general cooking times and the position of the tray for different types of foods. Personal experience will help to determine any variations in the values reported in the table. In any case, it is recommended to follow the instructions of the specific recipe being used.







Temperatures between brackets are referred to the use of oven with fan assisted gas.

TABLE N°8

GAS OVEN COOKING TABLE			
	TEMP °C	HEIGHT	MINUTES
MEAT			
PORK ROAST	220 (210)	4	60-70
BEEF ROAST (YOUNG STEER)	250 (240)	4	50-60
BEEF ROAST	240 (230)	4	60-70
VEAL ROAST	220 (210)	4	60-70
LAMB ROAST	220 (210)	4	45-55
ROAST BEEF	230 (230)	4	55-65
ROAST HARE	235 (225)	4	40-50
ROAST RABBIT	220 (210)	4	50-60
ROAST TURKEY	235 (225)	4	50-60
ROAST GOOSE	225 (215)	4	60-70
ROAST DUCK	235 (225)	4	45-60
ROAST CHICKEN	235 (225)	4	40-45
FISH			
	200-225 (190-215)	3	15-25
PASTRY			
FRUIT PIE	200 (210)	3	35-40
TEA CAKE	190 (180)	3	50-55
BRIOCHES	175 (165)	3	25-30
SPONGE CAKE	235 (225)	3	20
RING CAKE	190 (180)	3	30-40
SWEET PUFF PASTRIES	220 (210)	3	20
RAISIN LOAF	220 (210)	3	15-20
STRUDEL	180 (170)	3	15-20
SAVOIA COOKIES	190 (180)	3	15
APPLE FRITTERS	220 (210)	3	20
SAZOIARDI SANDWICH	220 (210)	3	20-30
TOAST SANDWICH	250 (240)	4	5
BREAD	220 (210)	3	30
PIZZA	220 (210)	3	20

**USING THE THERMOSTAT WITH SWITCH IN SERIES
(COOKERS WITH A SINGLE-CONTROL CONVENTIONAL ELECTRIC OVEN)**

The electric oven is controlled by an electric thermostat combined with a switch used to turn on the elements. The electric oven can be combined with an electric grill. The oven is heated by 2 elements: one on the top and one on the bottom. Turning the knob (fig.29) turns on the bottom element and the top external elements while the thermostat is used to set the temperature ranging from 50°C to 250°C. It can be adjusted using the scale indicated on the ring around the knob. An orange light turns off indicating that the temperature setting has been reached. Therefore, it is normal for this light to turn on and off while the oven is working. There are 3 fixed position beyond the 250°C setting:

- the symbol  or  indicates the only the bottom element (1300W M6; 1800 W M9) has been turned on;
 - the symbol  or  indicates that only the top external element (900W M6; 1200 W M9) has been turned on;
 - the symbol  or  indicates that only the grill element (1500W M6; 1800W M9) has been turned on;
- In these positions the temperature is not controlled by the thermostat.

USING THE ELECTRIC THERMOSTAT

The thermostat supplied with the relative models maintains a constant temperature inside the oven at a specific temperature setting ranging from 50°C to 250°C.(fig.30A-30B-30C)

Turn the knob clockwise and align the selected temperature indicated on the ring with the index etched on the control panel. Thermostat operation is indicated by an orange light which will turn off when the temperature inside the oven is 10°C greater than the temperature setting, and will turn on when the oven is 10°C less than the temperature setting. The thermostat can control the oven elements only if the relative switch is in one of the possible oven element operating modes: if the switch is in position 0, the thermostat has not effect on the oven elements, which remain off.



















USING THE 9 + 0 SWITCH (fig.31A-31B-31C)

The 9 + 0 switch installed in the multifunction oven models is used, along with the thermostat, to control the electric fan and the oven elements since they can be turned on by turning the 9 + 0 switch knob and the thermostat knob. Turning just one of the two knobs will not have any effect on the oven except to turn on the oven light or the electric fan when inserted. The electric oven is heated by 4 elements: one on the bottom, two on the top or one circular; turning the switch knob turns on the element relative to the symbol indicated on the ring but to be activated the thermostat knob must be turned until the orange light turns on indicating that the element has been turned on. Placing the switch knob on any of the nine operating modes turns on the oven light, together with the relative element. Once the temperature and the elements to be used have been set, the oven elements are turned on and off by the thermostat; therefore, it is normal for the orange light to turn on and off while the oven is working.



















To turn off the electric oven set the switch knob to position 0 to prevent the thermostat from controlling the elements. Setting the thermostat knob to position 0 turns off the elements but it is still possible, using the switch, to turn on the electric fan and the oven light.

The switch has 9 different fixed positions corresponding to 9 different types of oven operation:

For type M6V

- the symbol  or  indicates that only the oven light is turned on;
- the symbol  or  indicates that the bottom element (1300W) and the top external element (900W) have been turned on;
- the symbol  or  indicates that only the top external element (900W) has been turned on;
- the symbol  or  indicates the only the bottom element (1300W) has been turned on;
- the symbol  or  indicates that only the grill element (2000W) has been turned on;
- the symbol  or  indicates that the top external element (900W) and the grill element (2000W) have been turned on;
- the symbol  or  indicates that the top external element (900W), the grill element (2000W) and the electric fan have been turned on;
- the symbol  or  indicates that the circular element (2400W) and the electric fan have been turned on;
- the symbol  or  indicates that only the electric fan has been turned on.

For type M9V

- the symbol  or  indicates that only the oven light is turned on;
- the symbol  or  indicates that the bottom element (1800W) and the top external element (1200W) have been turned on;
- the symbol  or  indicates that only the top external element (1200W) has been turned on;
- the symbol  or  indicates the only the bottom element (1800W) has been turned on;
- the symbol  or  indicates that only the grill element (1800W) has been turned on;
- the symbol  or  indicates that the top external element (1200W) and the grill element (1800W) have been turned on;
- the symbol  or  indicates that the top external element (1200W), the grill element (1800W) and the electric fan have been turned on;
- the symbol  or  indicates that the circular element (3000W) and the electric fan have been turned on;
- the symbol  or  indicates that only the electric fan has been turned on.

When the knob is set to one of these nine positions, the oven light is always on, thus indicating that the oven is being energised.

USING THE NATURAL CONVENTIONAL ELECTRIC OVEN 

When using the oven for the first time it should be operated for a maximum of 30 minutes at a temperature of about 250° to eliminate any odours generated by the internal insulation. During normal oven use, select the desired cooking temperature using the thermostat knob and wait until the orange light turns off before putting in any food. The oven is equipped with 5 guides at different heights (fig.28) which can be used to insert shelves or the tray. To keep the oven as clean as possible it is recommended to cook meat on the tray or on the shelf that has been inserted inside the tray. Table No. 8 below lists the cooking times and the position of the tray for different types of foods. Personal experience will help to determine any variations in the values reported in the table. In any case, it is recommended to follow the instructions of the specific recipe being used.

TABLE N°8

NATURAL CONVENTIONAL ELECTRIC OVEN COOKING TABLE			
	TEMP °C	HEIGHT	MINUTES
MEAT			
PORK ROAST	225	4/5	60-80
BEEF ROAST (YOUNG STEER)	225	4/5	60-80
BEEF ROAST	250	4/5	50-60
VEAL ROAST	225	4/5	60-80
LAMB ROAST	225	4	40-50
ROAST BEEF	230	4/5	50-60
ROAST HARE	250	4/5	40-50
ROAST RABBIT	250	4	60-80
ROAST TURKEY	250	4	50-60
ROAST GOOSE	225	4	60-70
ROAST DUCK	250	4/5	45-60
ROAST CHICKEN	250	4/5	40-45
FISH			
	200-225	3	15-25

PASTRY			
FRUIT PIE	225	3	35-40
TEA CAKE	175-200	3	50-55
BRIOCHEs	175-200	3	25-30
SPONGE CAKE	220-250	3	20-30
RING CAKE	180-200	3	30-40
SWEET PUFF PASTRIES	200-220	3	15-20
RAISIN LOAF	250	3	25-35
STRUDEL	180	3	20-30
SAVOIA COOKIES	180-200	3	40-50
APPLE FRITTERS	200-220	3	15-20
SAZOIARDI SANDWICH	200-220	3	20-30
TOAST SANDWICH	250	4	5
BREAD	220	4	30
PIZZA	220	3	20

USING THE VENTILATED ELECTRIC OVEN

When using the oven for the first time it should be operated for a maximum of 30 minutes at a temperature of about 250° to eliminate any odours generated by the internal insulation.

Before cooking, allow the oven to reach the desired temperature setting waiting for the orange light to turn off. This type of oven is equipped with a circular element around which a fan has been installed that creates forced-air circulation in the horizontal direction. Thanks to this type of operation, the ventilated oven can be used for different types of cooking at the same time, without changing the taste of each food. Only some models are equipped with a removable metallic filter applied to the rear screen which collects the fat while a roast is cooking. Therefore, it is recommended to remove this fat periodically, washing the screen with soapy water and rinsing thoroughly. To remove the metallic filter just apply slight pressure toward the top on the tab indicated by the arrow. Hot-air circulation guarantees a uniform distribution of heat. Pre-heating the oven is not necessary, but for very delicate pastries, it is recommended to heat the oven before inserting the trays.

The ventilated conventional system partially changes the various notions about traditional cooking. Meat no longer needs to be turned while it is cooking and the rotisserie is no longer needed to cook a roast on the spit. Just put the meat directly on the shelf.

TABLE N°9

VENTILATED ELECTRIC OVEN COOKING TABLE			
	TEMP °C	HEIGHT	MINUTES
MEAT			
PORK ROAST	160-170	3	70-100
BEEF ROAST (YOUNG STEER)	170-180	3	65-90
BEEF ROAST	170-190	3	40-60
VEAL ROAST	160-180	3	65-90
LAMB ROAST	140-160	3	100-130
ROAST BEEF	180-190	3	40-45
ROAST HARE	170-180	3	30-40
ROAST RABBIT	160-170	3	80-100
ROAST TURKEY	160-170	3	160-240
ROAST GOOSE	160-180	3	120-160
ROAST DUCK	170-180	3	100-160
ROAST CHICKEN	180	3	70-90
FISH			
	160-180	3 / 4	
PASTRY			
FRUIT PIE	180-200	3	40-50
TEA CAKE	200-220	3	40-45
BRIOCHEs	170-180	3	40-60
SPONGE CAKE	200-230	3	25-35
RING CAKE	160-180	3	35-45
SWEET PUFF PASTRIES	180-200	3	20-30
RAISIN LOAF	230-250	3	30-40
STRUDEL	160	3	25-35
SAVOIA COOKIES	150-180	3	50-60
APPLE FRITTERS	180-200	3	18-25
SAZOIARDI SANDWICH	170-180	3	30-40
TOAST SANDWICH	230-250	4	7
BREAD	200-220	4	40
PIZZA	200-220	3	20

USING THE GAS GRILL

The gas grill can be combined only with the gas oven. It is controlled with the same gas oven knob (fig. 26A-26B-26C-26D), but turning it clockwise instead of counterclockwise (see the gas oven use instructions), matching the symbol with the indicator. The grill burner always operates at maximum and therefore there is no minimum position. In addition, it is equipped with a safety device to prevent the flame from going out. The gas grill can also be ignited in different ways:

- **Manual lighting:** Just completely open the oven door, turn the knob so that the relative symbol matches the indicator, while pressing the knob, and, at the same time, put a lit match next to the burner. Make sure that the burner is completely lit and after about 10 seconds release the knob. Make sure that the burner remains on, otherwise repeat the operation.

- **Electric ignition:** In this case, completely open the oven door, turn the knob so that the relative symbol matches the indicator, then press the thermostat knob (models with ignition trough knob). Wait about 10 seconds after the burner has been completely lit and then release the knob. Make sure that the burner remains on, otherwise repeat the operation. As for cookers without ignition trough knob, press the thermostat knob and the key with the spark symbol, wait about 10 seconds after the burner has been completely lit and then release the knob. Make sure that the burner remains on, otherwise repeat the operation.

WARNING: As with the oven, the grill must be lit with the door completely open.

The gas grill can be used to grill foods on the oven shelf or using the rotisserie.

Grilling on the shelf: In this case, the shelf supplied is placed on level 1 or 2 and the foods to be grilled are placed on top, while the tray is inserted on the lower levels to collect the cooking juices.

Then light the grill burner according to the instructions described above.

IMPORTANT: grill foods on the shelf always with the door semi-open (fig. 35) and, to avoid overheating, mount the handle guard on the relative latches (fig. 32).

Grilling with the rotisserie: This is used to grill with the rotating skewer. Therefore, insert the skewer holder on the side shelves at level 3. Insert the food on the skewer and insert everything into the oven, inserting the point of the skewer into the spindle that projects out from the rear or left side of the oven and resting the front of the skewer into the skewer holder support (Fig. 33 for cooker type M6V) (Fig. 34 for cooker type M9V). Then, insert the tray into one of the lower guides and press the button that starts the rotisserie. Then light the grill burner according to the instructions described above.

IMPORTANT: grill foods with the rotisserie always with the door open (fig. 36) for cooker type M6V and with the door semi-open (fig. 35) for cooker type M9V and, to avoid overheating, mount the handle guard on the relative latches (fig. 32).

WARNING: the accessible parts may become very hot while grilling. Keep children away from the appliance while cooking.

USING THE CONVENTIONAL ELECTRIC GRILL

The electric grill can also be combined with the gas oven or electric oven.

In both cases, the grill is controlled using the oven's temperature knob (see also, Using the gas or electric oven). Like the gas grill, the electric grill can be used for grilling on the oven's grill or using the roasting spit.

The static electric grill must be used with the door closed. The temperature set on the thermostat (when present) must not exceed 150°C.

The power of the electric grill for M6 cookers with gas oven is 1500W whereas for M9 cookers with gas oven it is 1800W.

Grilling on the shelf: In this case, the shelf supplied is placed on level 1 or 2 and the foods to be grilled are placed on top, while the tray is inserted on the lower levels to collect the cooking juices. Then turn on the grill element switching the thermostat to the relative position (electric oven version).

Grilling with the rotisserie: This is used to grill with the rotating skewer. Therefore, insert the skewer holder on the side shelves at level 3. Insert the food on the skewer and insert everything into the oven, inserting the point of the skewer into the spindle that projects out from the rear or left side of the oven and resting the front of the skewer into the skewer holder support. Then, insert the tray into one of the lower guides and switch the thermostat to the relative position and press the button with the rotisserie symbol (electric oven version).

WARNING: the accessible parts may become very hot while grilling. Keep children away from the appliance while cooking.

USING THE VENTILATED ELECTRIC GRILL

The ventilated electric grill is a special function equipped only on the multifunction oven. Set the 9 + 0 switch to the relative position to activate the grill element (2900W) and the electric fan. Generally, to ensure excellent grilling, place the oven shelf in the middle position while the oven tray should be inserted at the bottom.

IMPORTANT: When using the ventilated electric grill, set the thermostat knob no higher than 175 °C, which is between the 150 °C and 200 °C setting, to avoid overheating the front of the appliance. In fact, ventilated grilling must be carried out with the door closed.

USING THE MINUTE-MINDER (fig.37A-37B-37C)

The minute-minder advises the user, with an acoustic signal, when food has been cooked, after a certain time period has elapsed. To use the device, wind the minute-minder by turning the knob clockwise one complete turn. Then turn the knob counterclockwise so that the indicator corresponds with the selected cooking time.

WARNING: the acoustic signal does not stop the cooking cycle. The use must turn off the cooking cycle by hand using the relative knobs.

ANALOGUE CLOCK WITH TIMER (fig. 38)

The analogue clock with timer lets you know when the cooking is finished thanks to an acoustic signal.

To set the clock, push and contemporarily turn the pivot clockwise until you reach the chosen time; let the pivot, then turn it clockwise again (without pushing) until the ring is positioned on the crossed bell: in this way only the clock will be functioning.

To use the timer, turn the pivot clockwise without pushing and choose, using the ring, the cooking time; once the time is over, the clock will alert you with an acoustic signal.

PLEASE NOTICE that the acoustic signal does not interrupt the cooking process. To stop it, it is necessary to switch off manually the corresponding buttons.

ELECTRONIC TIMER (fig. 39)

Setting

Select a function by pressing the function button and set the required time with the +/- buttons.

+/- buttons

pressing the "+" button increases the time set, pressing "-" decreases it. The count-up or count down speed increases the longer the button is held in appropriate position

setting time of day

select time of day function by pressing the duration and end time button together and set time of day with +/- buttons.

Any programme which has been set is cancelled and the outputs switched on

Manual operation

Press duration and end time button together. The relay contacts will switch on. The "A" symbol will be erased, the pot symbol illuminated. Any programme which has been set is cancelled.

Semi-automatic operation with cooking duration

Select cooking duration function and set required duration with +/- button. "A" and cookpot symbol appear. The relay output becomes active. If time of day = cooking end time the relay output and the cookpot symbol are switched off.

The audible signal sounds. The symbol "A" blinks.

Semi-automatic operation with cooking end time

Select cooking end time function and set required duration with +/- button. "A" and cookpot symbol appear. The relay output becomes active. If time of day = cooking end time the relay output and the cookpot symbol are switched off.

The audible signal sounds and "A" blinks.

Fully automatic operation

Select cooking duration function and set required duration with +/- button. The "A" symbol appears. The relay is switched on and the cookpot symbol appears. Select cooking end time function and the earliest possible end time is displayed. Set the required end time with the +/- button. The relay and the cookpot symbol are switched off.

The cookpot symbol appears again when time of day = the calculated start time.

After the automatic programme has ended, the symbol "A" blinks.

The audible signal is heard and the cookpot symbol and the relay are switched off.

Minute minder

Select minute minder button and set required time with +/- button. As the time set elapses the symbol bell symbol is displayed. After the time set has elapsed, the audible signal sounds.

Audible signal

The audible signal sounds at the end of a minute minder cycle or of a cooking programme for a period of 7 minutes. The signal can be cancelled by pressing any function button. Pressing the "-" button without having previously selected a function the frequency of the signal changes. A selection from 3 possibilities can be made. The selected signal is audible as long as time "-" button is pressed.

Programme start and verification

A programme which has been set is carried out after setting the time required. The "time to run" can be verified at any time by selecting the appropriate function.

Setting error identification

The setting is correct if time of day is in between the calculated cooking start and end times. If an error has been made, this will be indicated by the audible signal and by the symbol "A" flashing. The faulty setting can be corrected by changing one or both functions.

Cancelling programme

A programme can be cancelled by selecting the manual function. After a programme which has been set comes to an end, it is automatically cancelled.

CLEANING THE APPLIANCE

Before cleaning the appliance, it should be disconnected from the power supply and turn off the main gas feeder valve.

Cleaning the work surface:

Periodically clean the burner heads, the enamelled steel grids, the enamelled covers and the flame caps using warm soapy water. Then those parts should be rinsed and thoroughly dried.

Any liquid that overflows from pots must always be removed using a rag.

If it becomes difficult to open or close a valve, do not force it, but immediately request the assistance of the technical service personnel.

Cleaning the enamelled parts:

To maintain the original features of the enamelled parts they should be cleaned frequently with soapy water. Never use abrasive powders. Do not leave acidic or alkaline substances on the enamelled parts (vinegar, lemon juice, salt, tomato sauce, etc.) and do not wash the enamelled parts while they are still hot.

Cleaning the STAINLESS steel parts:

Clean the parts with soapy water and then dry them with a soft cloth. The shine is maintained by periodically using special products that generally are found in the market. Never use abrasive powders.

Cleaning the burner flame caps:

Since the flame caps are resting on the burner, to clean them just remove them from their seat and wash them with soapy water. After they have been thoroughly dried and having checked that the holes are not clogged, they can be replaced in their proper position.

Cleaning the inside of the oven glass:

One of the features of the oven is the possibility of removing the interior glass simply by loosening the 2 screws **B** (fig. 41), to clean the inside surface of the glass (fig. 40). This operation should be carried out while the oven is cold and with a damp cloth. Do not use abrasives.

Cleaning the inside of the oven:

To thoroughly clean the inside of the oven, it is recommended to disassemble the door by carefully following the instructions described below. Insert the hook **C** (figure 42) into the hinged sector **D**. Put the door in a semi-open position and using both hands pull it towards you until it is released from the attachment. To replace the door, do the opposite making sure to insert the two sectors **F** correctly. In addition, the side shelves can be removed very easily, by loosening the lock rings that attach them to the oven.

AFTER-SALES TECHNICAL SERVICE AND SPARE PARTS

Before leaving the factory, this appliance was tested and calibrated by skilled and qualified personnel.

Any repairs or calibration that may become necessary after leaving the factory should be performed by skilled personnel. For this reason we advise the customer to contact the Dealer that sold the appliance or the nearest Service Centre, providing them with information about the type of appliance and the type of problem that has occurred. If defective parts must be replaced, it is recommended to replace them with original spare parts that are available only in our technical Service Centres and authorised dealers.

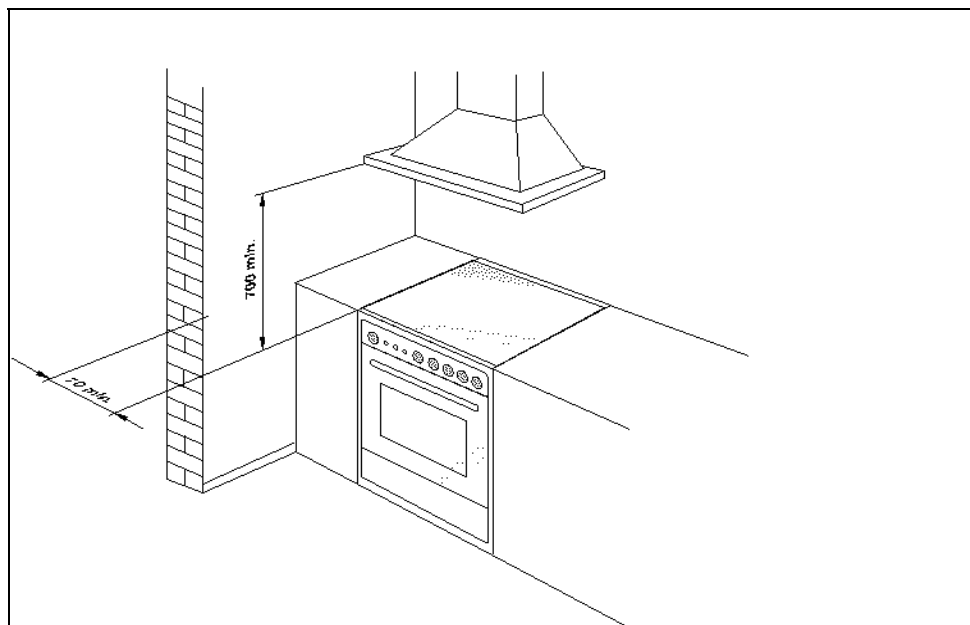

Fig. 1

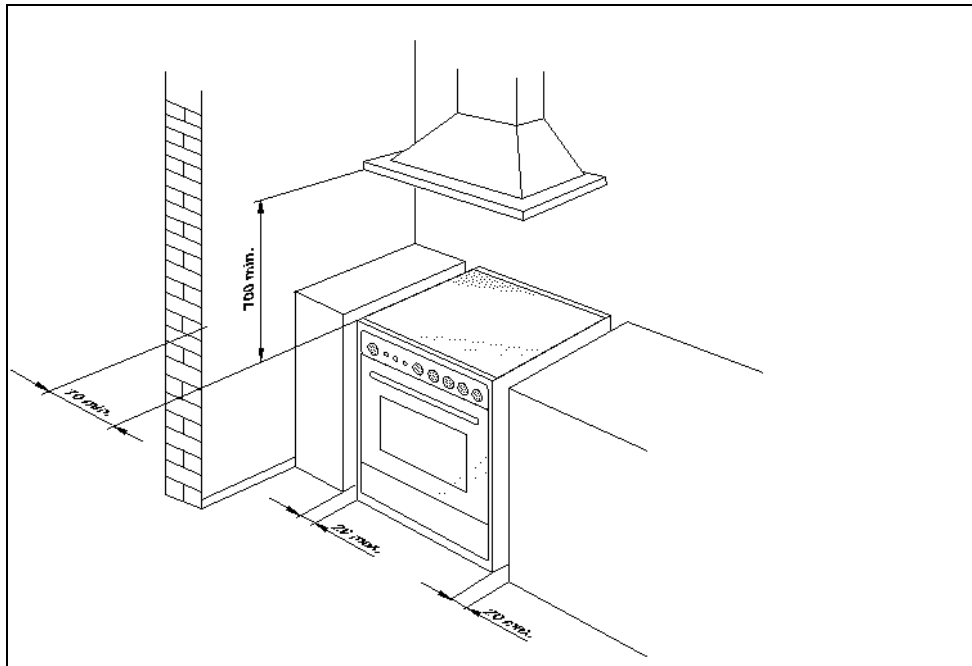

Fig. 2

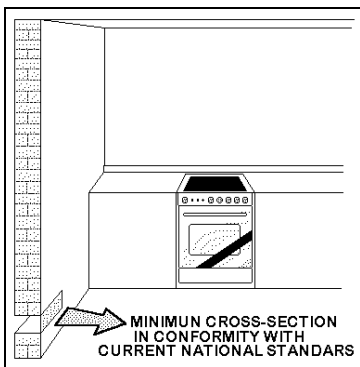

Fig. 3

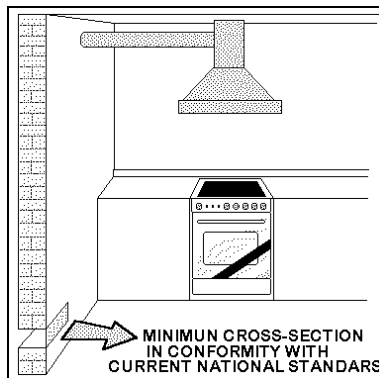

Fig. 4

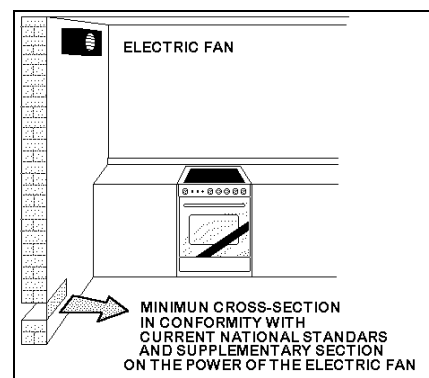

Fig. 5

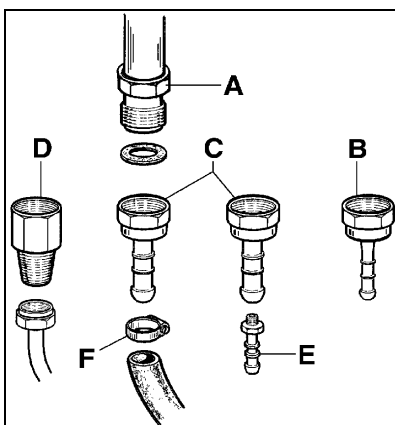

Fig. 6

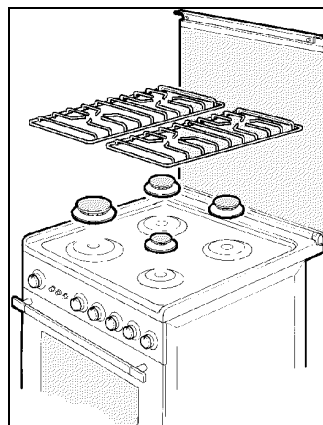

Fig. 7A

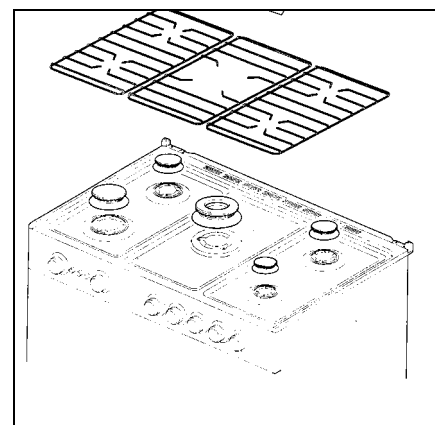

Fig. 7B

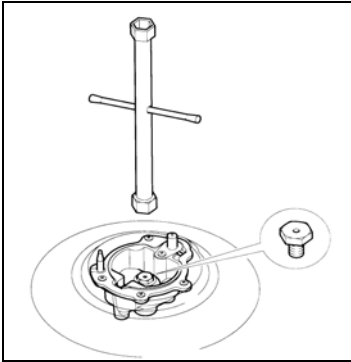

Fig. 8

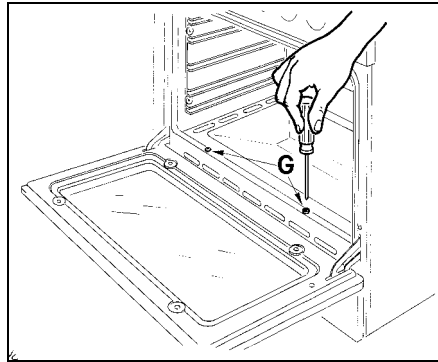

Fig 9A

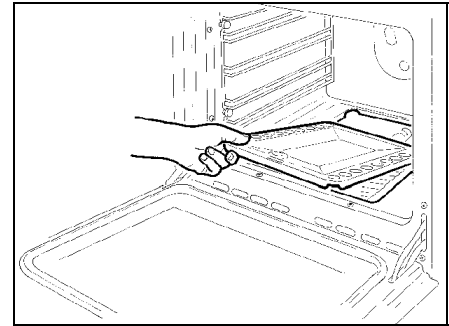

Fig. 9B

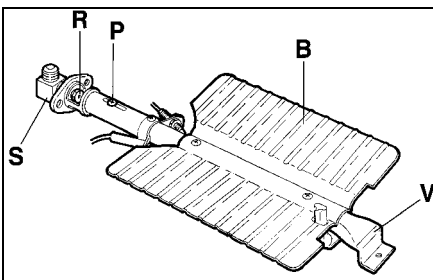

Fig. 10A

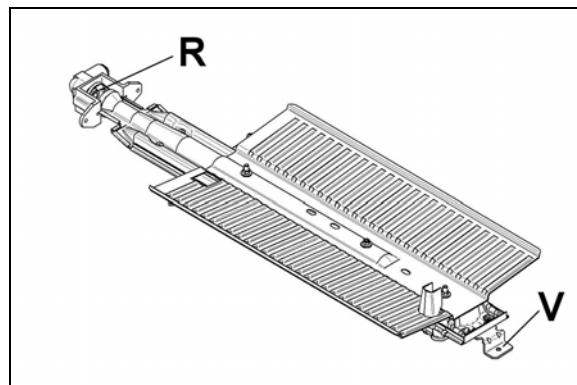

Fig. 10B

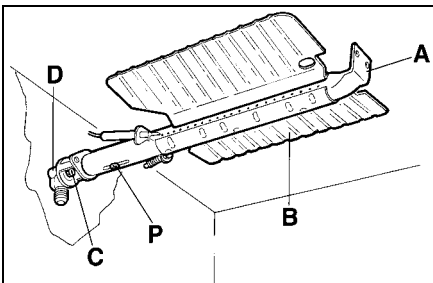

Fig 11A

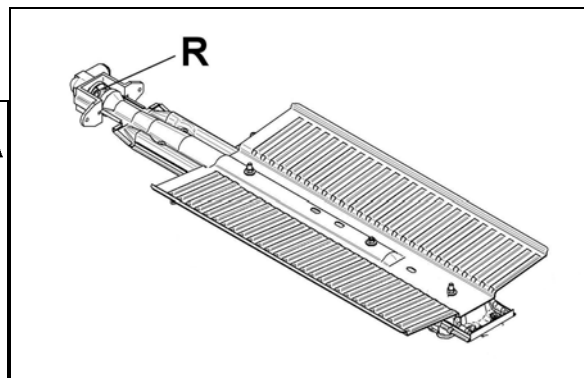

Fig 11B

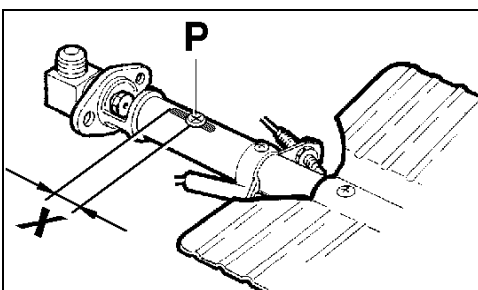

Fig 12

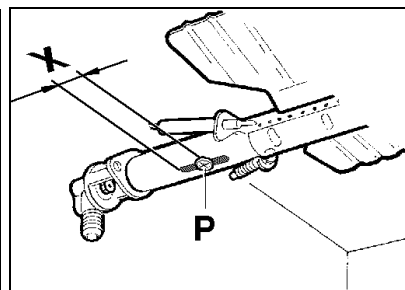

Fig 13

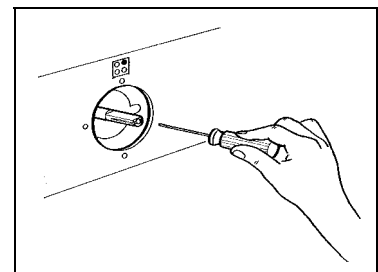

Fig. 14

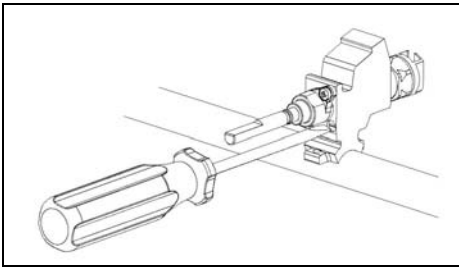

Fig. 15

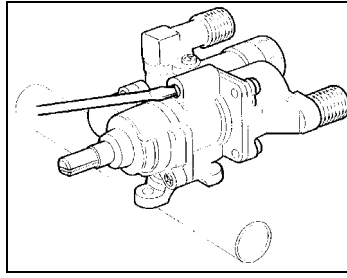

Fig. 16

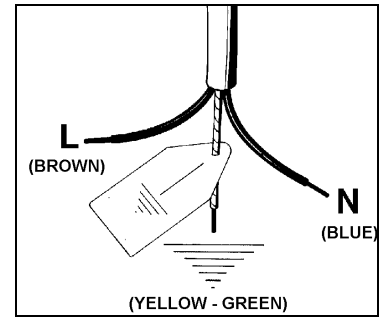

Fig. 17

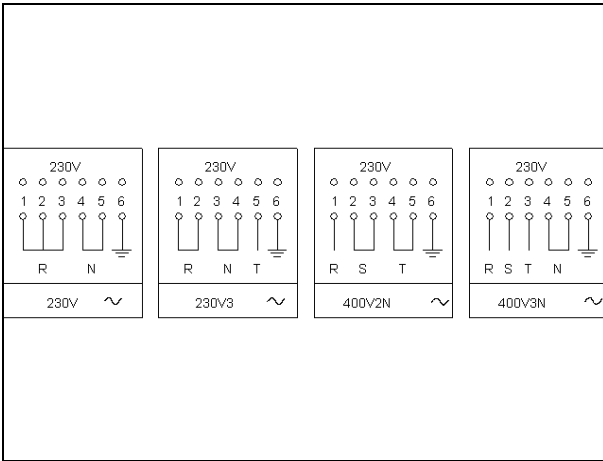

Fig. 18

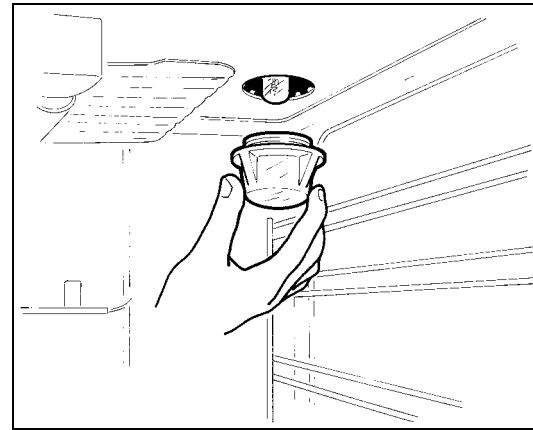

Fig. 19

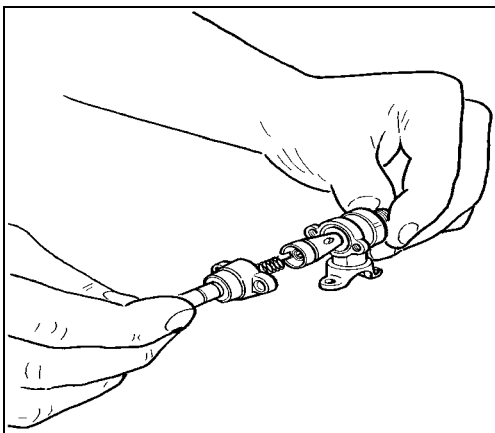

Fig. 20

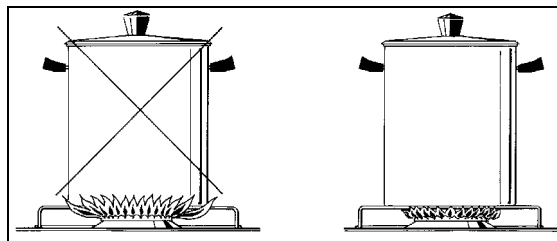

Fig. 21

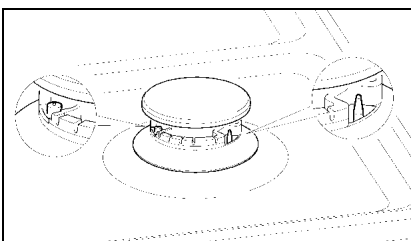

Fig. 22

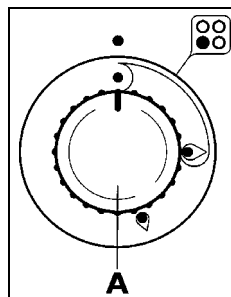

Fig. 23 A

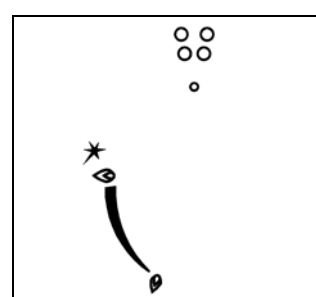

Fig. 23 B

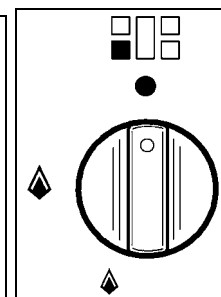

Fig. 23 C

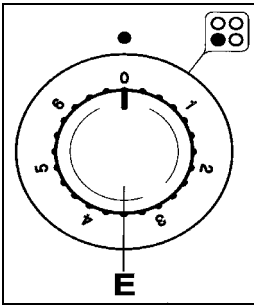

Fig. 24A

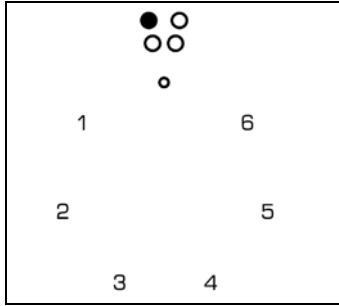

Fig. 24B

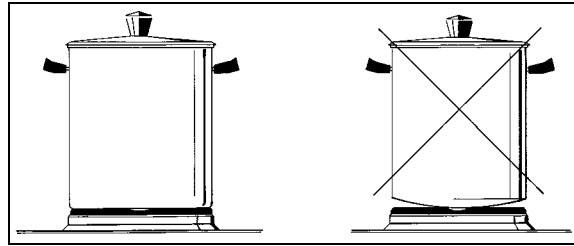

Fig. 25

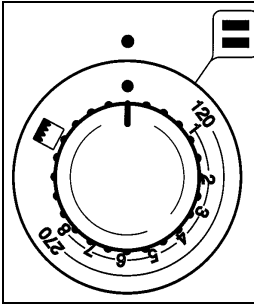

Fig. 26A

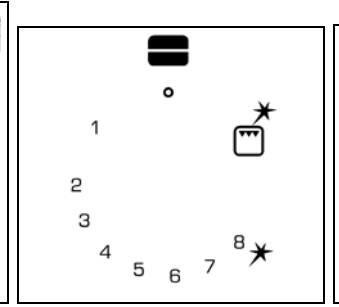

Fig. 26B

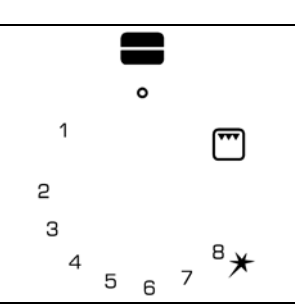

Fig. 26C

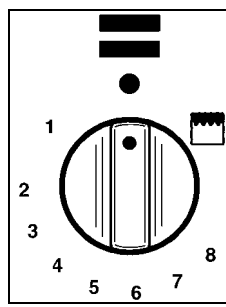

Fig. 26D

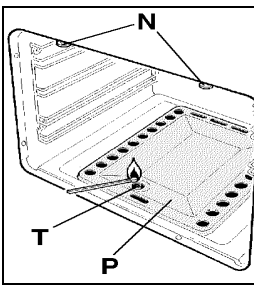

Fig. 27A

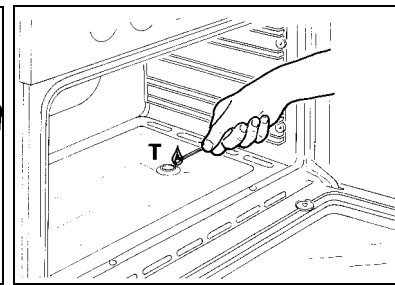

Fig. 27B

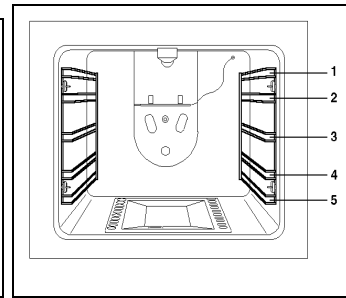

Fig. 28

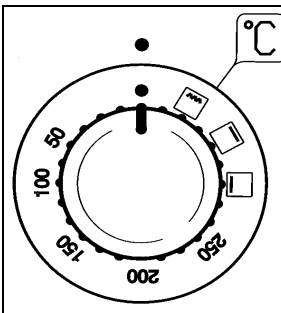

Fig. 29

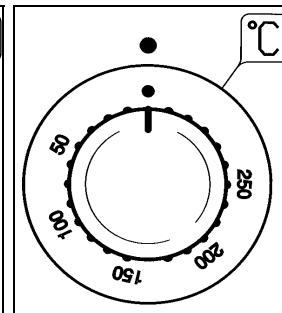

Fig. 30A

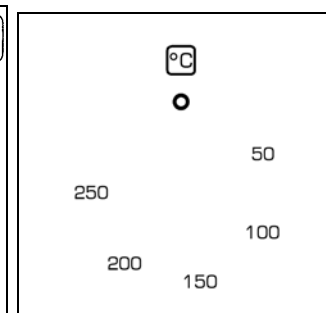

Fig. 30B

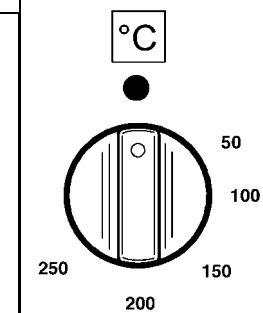

Fig. 30C

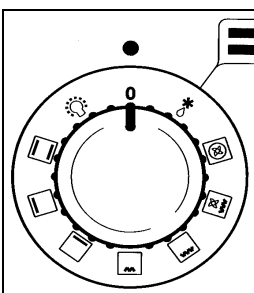

Fig. 31A

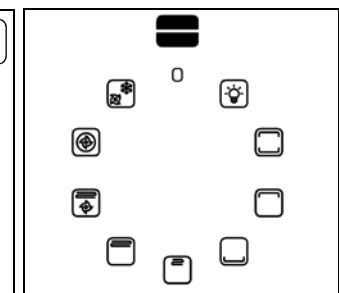

Fig. 31B

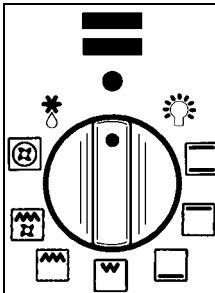

Fig. 31C

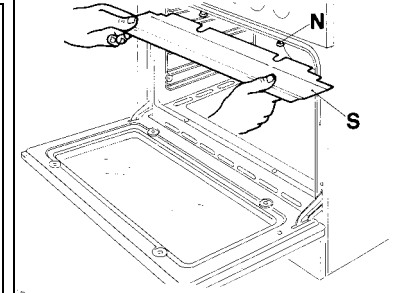

Fig. 32

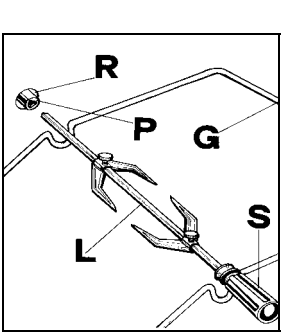

Fig. 33

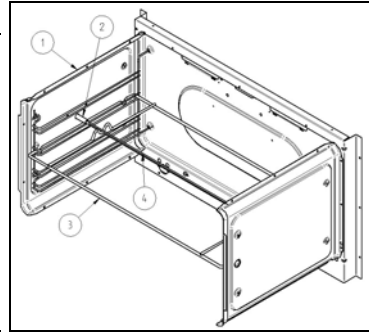

Fig. 34

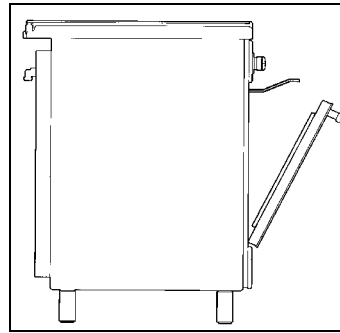

Fig. 35

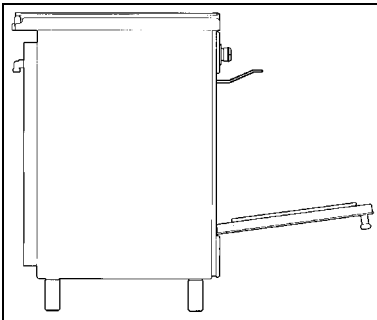

Fig. 36

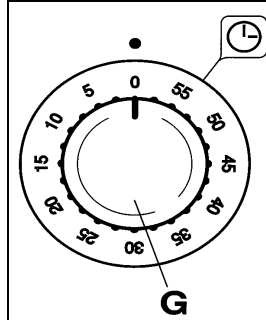

Fig. 37A

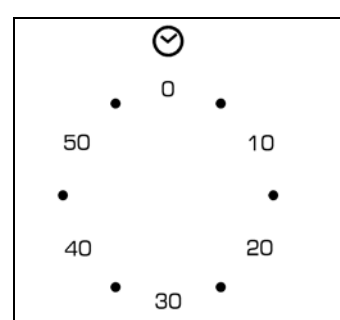

Fig. 37B

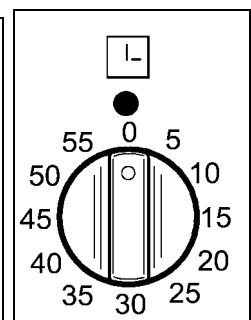

Fig. 37C

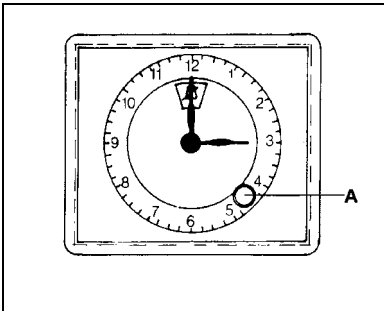

Fig. 38

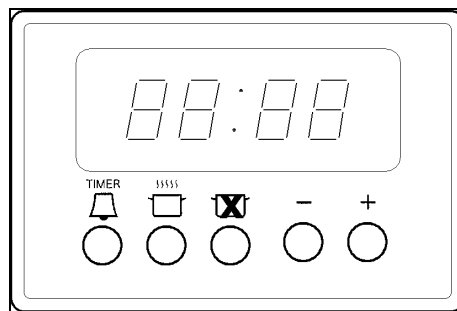

Fig. 39

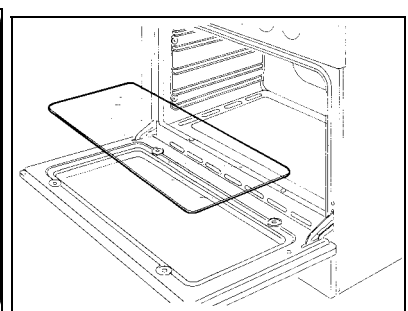

Fig. 40

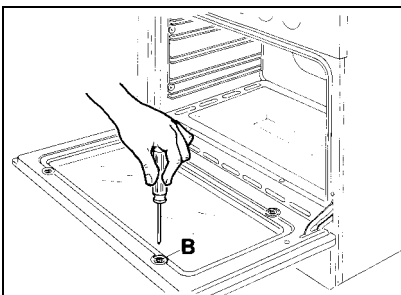

Fig. 41

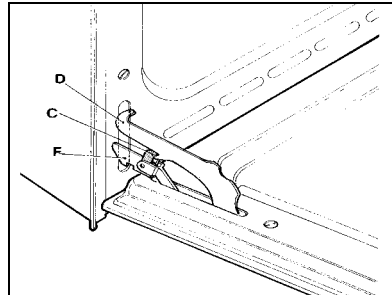

Fig. 42

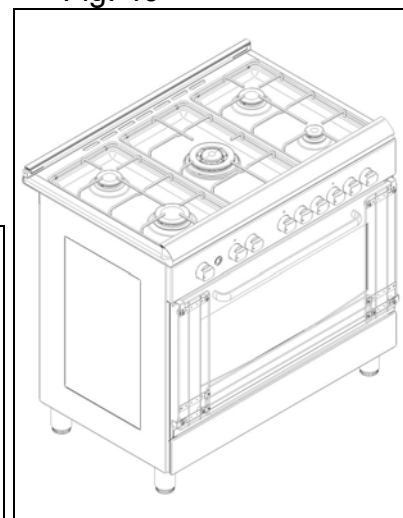

Fig. 43



310223